

Power System SR



Installation and Application Instruction

Our products from the division BUILDING SOLUTIONS

SERVICES

- » On-site tests -> we ensure that your requirements are properly covered by our planning.
- » Test reports -> for your safety and documentation.
- » Trainings -> the knowledge of your employees from planning and production is enhanced by our experts on site, online or via webinar.
- » Planning support -> latest design software, planning documents, CAD data and much more can be downloaded any time from www.philipp-group.de.

HIGH DEMANDS ON PRODUCT SAFETY AND PRACTICALITY

- » Close cooperation with notified bodies and - if necessary - approval of our solutions.

TECHNICAL DEPARTMENT

- » Our expert-team will support you at any time during your planning phase with detailed advice.

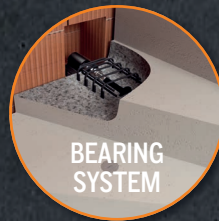
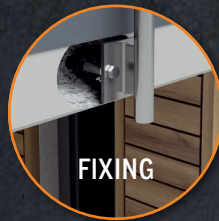
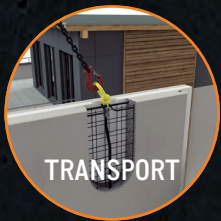

CONTENT

PHILIPP POWER SYSTEM SR	Page	4
Types, load bearing capacities and colour coding	Page	4
Comparison – Power System SR / system RD	Page	5
SYSTEM OVERVIEW	Page	6
COMBINATIONS - POWER SYSTEM SR	Page	9
GENERAL NOTES	Page	10
NOTES ON REINFORCEMENT	Page	12
THREADED TRANSPORT ANCHOR SR - STRAIGHT TAIL	Page	13
THREADED TRANSPORT ANCHOR SR - STRAIGHT TAIL - IN WALL-LIKE ELEMENTS	Page	14
Axial tension	Page	14
Diagonal tension	Page	15
Lateral tension	Page	16
THREADED TRANSPORT ANCHOR SR - STRAIGHT TAIL - IN WALL-LIKE ELEMENTS (INCLINED INSTALLATION)	Page	18
COMPACT ANCHOR SR	Page	21
COMPACT ANCHOR SR - IN WALL-LIKE ELEMENTS	Page	22
Axial tension	Page	22
Diagonal tension	Page	23
Lateral tension	Page	24
COMPACT ANCHOR SR - SHORT	Page	26
COMPACT ANCHOR SR - SHORT - IN WALL-LIKE ELEMENTS	Page	27
Axial tension / diagonal tension	Page	27
ANCHOR ELONGATION SR	Page	28
ACCESSORIES FOR THE POWER SYSTEM SR	Page	31
Marking ring SR (plastic)	Page	31
Plastic recess former SR	Page	32
Steel recess former	Page	33
Magnetic recess former	Page	34
Plastic recess former SR SZ15	Page	35
Steel recess former SZ15	Page	36
Key for Plastic recess former	Page	37
Plastic sealing cap	Page	38
Sealing cap (concrete)	Page	39
Sealing cap (stainless steel)	Page	40
LIFTY SR	Page	41
LIFTY SR DS	Page	43
SAFETY NOTES / INSPECTION	Page	45
Replacement state of Lifty SR	Page	45
Replacement state of Lifty SR DS	Page	46
Measure of wear	Page	46

THREADED TRANSPORT ANCHOR SYSTEMS

TYPES, LOAD BEARING CAPACITIES AND COLOUR CODING

System RD
(standard)



Example: Type RD 24 (2.5 t)

Power System SR
(heavy-duty right-hand)



Example: Type SR 16 (2.5 t)

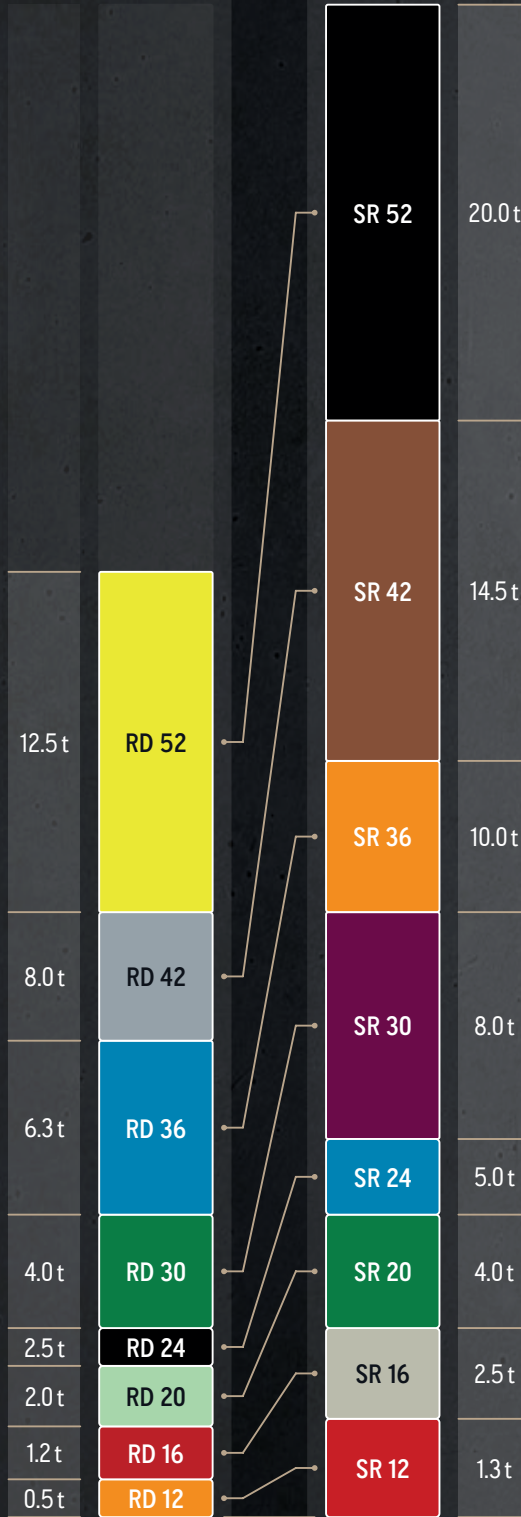

SYSTEM RD VS POWER SYSTEM SR

The Power System SR is an optimized threaded transport anchor system from PHILIPP. The eight thread sizes of the Power System SR each achieve higher load capacities (up to a load capacity of 20.0 t) than the standard threaded transport anchor system. In order to avoid any mix-up of the systems, the Power System SR is equipped with black chromatised threaded sleeves for a visual differentiation. In addition, the colour coding differs from the standard RD system.

SYSTEM RD

- » Wide range of anchor types for many applications
- » Different lifting devices available, from the simple Lifting loop with threaded end to the highly flexible Wirbelstar
- » Colour coding familiar for many years
- » All safety requirements in accordance with the Machinery Directive are met (CE marking)
- » Lifting inserts are available in galvanised or stainless steel version

POWER SYSTEM SR

- » Significantly higher load bearing capacities compared to the standard RD system with the same thread size
- » High specialised system of transport anchors, lifting devices and accessories
- » Special colour coding
- » Safe lifting and mounting of large/heavy reinforced concrete elements
- » All safety requirements in accordance with the Machinery Directive are met (CE marking)
- » Easily recognisable by black chromated threaded inserts

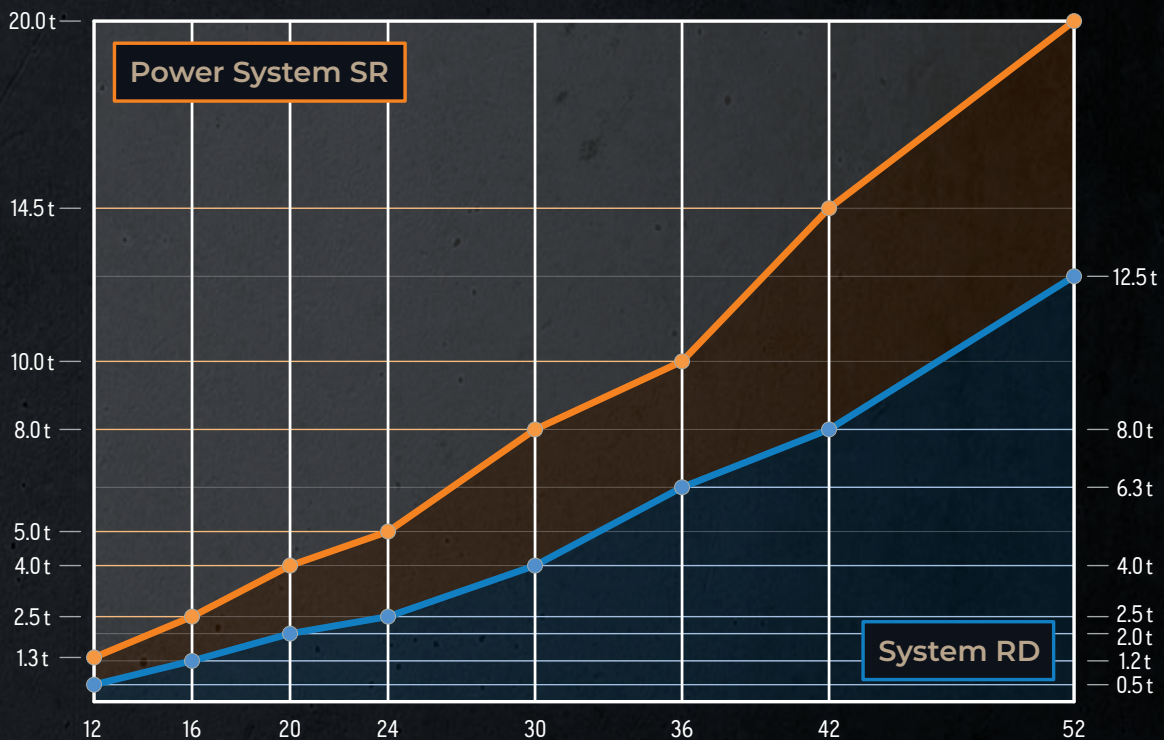

NOTE:

The use of PHILIPP transport anchors SR requires the application of corresponding lifting devices such as Lifty SR or Lifty SR DS, otherwise the specified load bearing capacities cannot be guaranteed!

SYSTEM OVERVIEW

THREADED TRANSPORT ANCHOR SR - STRAIGHT TAIL PAGE 13

Type	Load class	Ref. no.	
SR 12	1.3	67M12SR	
SR 16	2.5	67M16SR	
SR 20	4.0	67M20SR	
SR 24	5.0	67M24SR	
SR 30	8.0	67M30SR	
SR 36	10.0	67M36SR	
SR 42	14.5	67M42SR	
SR 52	20.0	67M52SR	

COMPACT ANCHOR SR PAGE 21

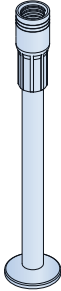
Type	Load class	Ref. no.	
SR 12	1.3	67K120130SR	
SR 16	2.5	67K160200SR	
SR 20	4.0	67K200258SR	
SR 24	5.0	67K240325SR	
SR 30	8.0	67K300400SR	
SR 36	10.0	67K360475SR	
SR 42	14.5	67K420550SR	

COMPACT ANCHOR SR - SHORT PAGE 26

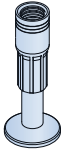
Type	Load class	Ref. no.	
SR 16	2.5	67K160090SR	
SR 24	5.0	67K200125SR	

ANCHOR ELONGATION SR PAGE 28

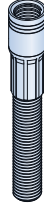
Type	Load class	Ref. no.	
SR 12	1.3	67AVLSR12_	
SR 16	2.5	67AVLSR16_	
SR 20	4.0	67AVLSR20_	
SR 24	5.0	67AVLSR24_	
SR 30	8.0	67AVLSR30_	
SR 36	10.0	67AVLSR36_	
SR 42	14.5	67AVLSR42_	
SR 52	20.0	67AVLSR52_	

MARKING RING SR WITH CLIP PAGE 31

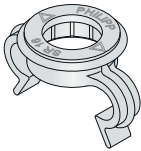
Type	Ref. no.	
SR 12	74KR12CLIPSR	
SR 16	74KR16CLIPSR	
SR 20	74KR20CLIPSR	
SR 24	74KR24CLIPSR	
SR 30	74KR30CLIPSR	
SR 36	74KR36CLIPSR	
SR 42	74KR42CLIPSR	
SR 52	74KR52CLIPSR	

PLASTIC RECESS FORMER SR PAGE 32

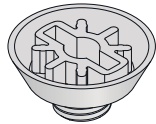
Type	Ref. no.	
SR 12	72KHN12SR	
SR 16	72KHN16SR	
SR 20	72KHN20SR	
SR 24	72KHN24SR	
SR 30	72KHN30SR	
SR 36	72KHN36SR	
SR 42	72KHN42SR	
SR 52	72KHN52SR	

STEEL RECESS FORMER PAGE 33

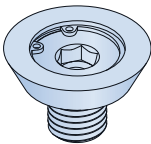
Type	Ref. no.	
M 12	72KHN12STK	
M 16	72KHN16STK	
M 20	72KHN20STK	
M 24	72KHN24STK	
M 30	72KHN30STK	
M 36	72KHN36STK	
M 42	72KHN42STK	
M 52	72KHN52STK	

MAGNETIC RECESS FORMER PAGE 34

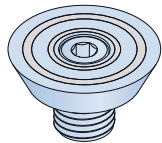
Type	Ref. no.	
M 12	72MAXKHN12	
M 16	72MAXKHN16	
M 20	72MAXKHN20	
M 24	72MAXKHN24	
M 30	72MAXKHN30	
M 36	72MAXKHN36	
M 42	72MAXKHN42	
M 52	72MAXKHN52	

SYSTEM OVERVIEW

PLASTIC RECESS FORMER SR-SZ15

PAGE 35

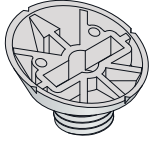
Type	Ref. no.	
SR 16	72KHN16SR-SZ15	
SR 20	72KHN20SR-SZ15	
SR 24	72KHN24SR-SZ15	
SR 30	72KHN30SR-SZ15	
SR 36	72KHN36SR-SZ15	
SR 42	72KHN42SR-SZ15	
SR 52	72KHN52SR-SZ15	

STEEL RECESS FORMER SZ15

PAGE 36

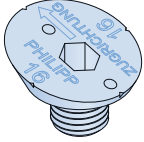
Type	Ref. no.	
M 16	72KHN16-SZ15	
M 20	72KHN20-SZ15	
M 24	72KHN24-SZ15	
M 30	72KHN30-SZ15	
M 36	72KHN36-SZ15	
M 42	72KHN42-SZ15	
M 52	72KHN52-SZ15	

KEY FOR PLASTIC RECESS FORMER

PAGE 37

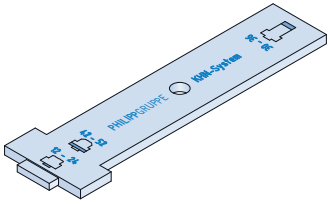
Type	Ref. no.	
M 16 - 52	72KHNS	

SEALING CAP (STAINLESS STEEL)

PAGE 40

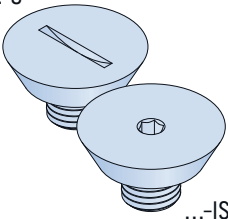
Type	Ref. no.	Slot / inner hexagon
M 12	72ASKHN12VA-...	 <p>...-S ...-ISK e.g. 72ASKHN16VA-S</p>
M 16	72ASKHN16VA-...	
M 20	72ASKHN20VA-...	
M 24	72ASKHN24VA-...	
M 30	72ASKHN30VA-...	
M 36	72ASKHN36VA-...	
M 42	72ASKHN42VA-...	
M 52	72ASKHN52VA-...	

SEALING CAP (PLASTIC)

PAGE 38

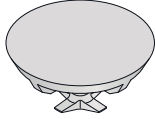
Type	Ref. no.	
M 12 / 16	72ASKHN040	
M 20 / 24	72ASKHN055	
M 30 / 36	72ASKHN070	
M 42 / 52	72ASKHN096	

SEALING CAP (CONCRETE)

PAGE 39

Type	Ref. no.	
M 12 / 16	72ASKHN040FB	
M 20 / 24	72ASKHN055FB	
M 30 / 36	72ASKHN070FB	
M 42 / 52	72ASKHN096FB	

LIFTY SR

PAGE 41

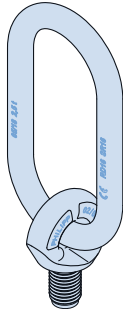
Type	Ref. no.	
SR 12	62LISR12	
SR 16	62LISR16	
SR 20	62LISR20	
SR 24	62LISR24	
SR 30	62LISR30	
SR 36	62LISR36	
SR 42	62LISR42	
SR 52	62LISR52	

LIFTY SR DS

PAGE 43

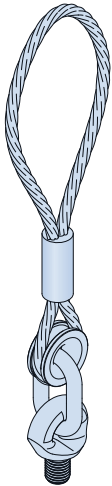
Type	Ref. no.	
SR 12	62LISR12DS	
SR 16	62LISR16DS	
SR 20	62LISR20DS	
SR 24	62LISR24DS	
SR 30	62LISR30DS	
SR 36	62LISR36DS	
SR 42	62LISR42DS	

POWER SYSTEM SR

The PHILIPP Power System SR is a well-matched combination of the SR threaded transport anchors, the lifting devices Lifty SR or Lifty SR DS and the corresponding recess formers plus sealing caps.

FEATURES

- » Stand-alone transport anchor system with high load-bearing capacities
- » Matching system components with consistent colour coding
- » Flexibility in the choice of transport anchors and lifting devices
- » Wide range of standard accessories

COMBINATIONS

- » Lifting devices SR
 - › Lifty SR
 - › Lifty SR DS
- » Recess formers SR
 - › Plastic recess former SR
 - › Steel recess former
 - › Magnetic recess former
- » Sealing caps
 - › Sealing cap (plastic)
 - › Sealing cap (stainless steel)
 - › Sealing cap (concrete)
- » Marking ring SR with clip
- » Transport anchors SR
 - › Threaded transport anchor SR
 - › Compact anchor SR
 - › Compact anchor SR - short
 - › Elongation for Threaded transport anchor SR

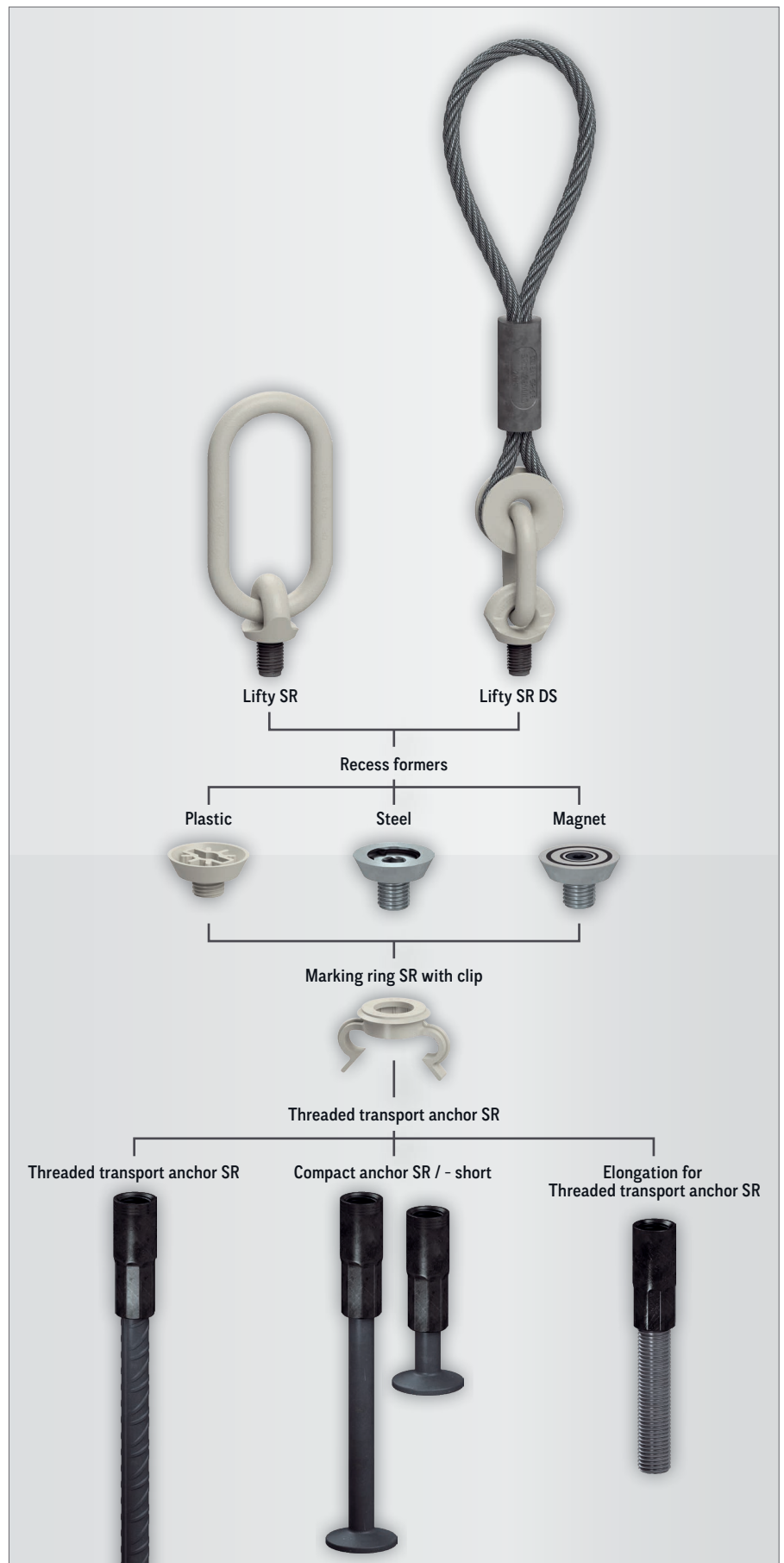

POWER SYSTEM SR • INCLINED INSTALLATION BY USING THE RECESS FORMER SR SZ15

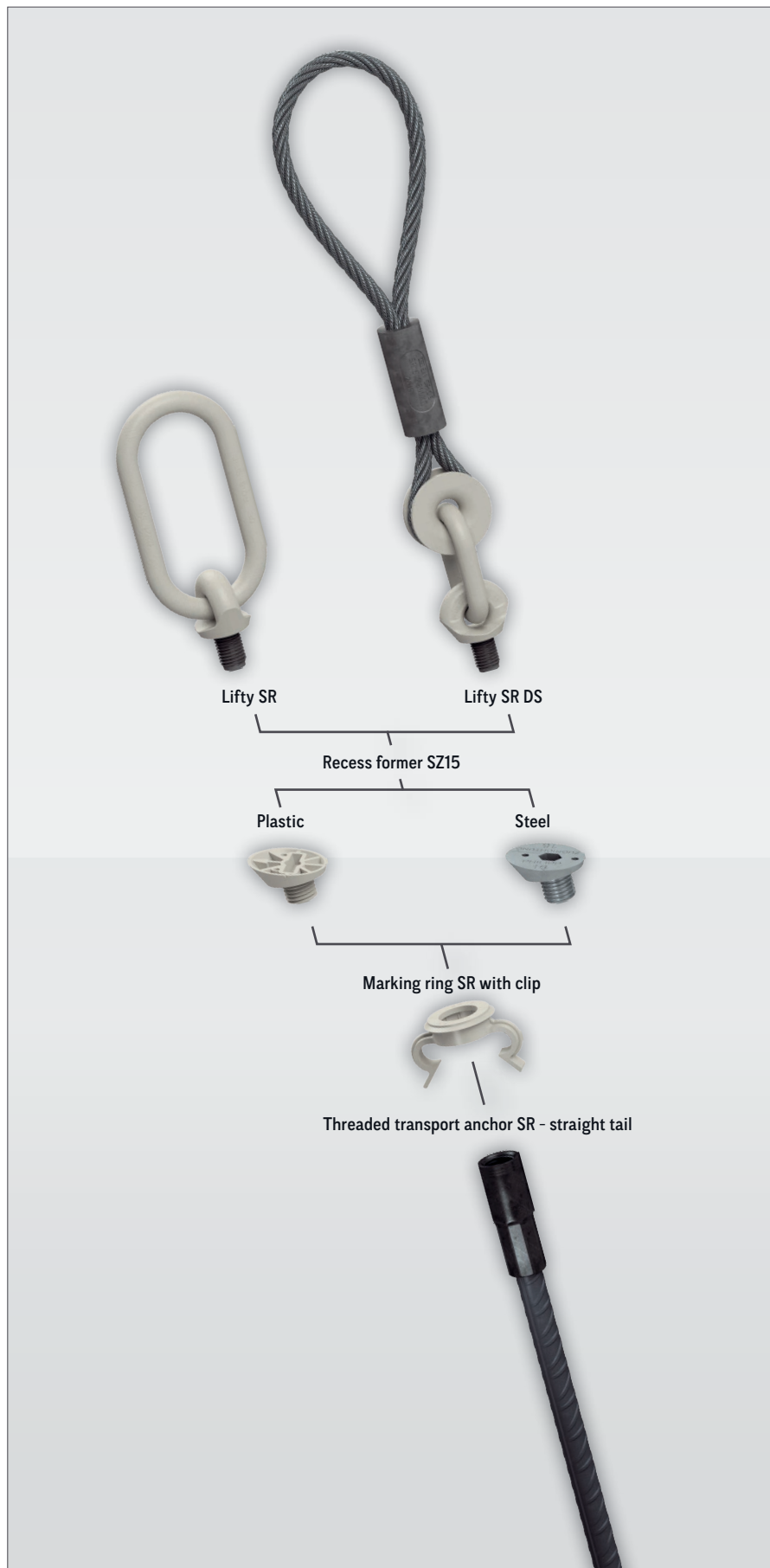

By inclining the transport anchor with 15°, it is possible to eliminate the need for additional reinforcement for diagonal tension. The Recess former SR SZ15 is the key element of this function and also supplements the SR transport anchor system with this savings option.

CHARACTERISTICS

- » No rebar for diagonal tension required
- » Integral component of the SR system, can be combined with all transport anchors and lifting devices contained therein
- » Increased safety through reduction of application errors
- » Special colour scheme of the SR system, ensuring clear assignment
- » Recess formers available in both durable plastic and steel

COMBINATIONS

- » Lifting devices SR
 - › Lifty SR
 - › Lifty SR DS
- » Recess formers SR SZ15
 - › Plastic recess former SR
 - › Steel recess former
- » Sealing caps (plastic)
 - › Outside cap (72ASS_)
 - › Sealing cap (72KAS_)
- » Marking ring SR with clip
- » Transport anchor
 - › Threaded transport anchor SR



RECESS FORMER SZ15

A combination of the Recess former SR SZ15 is only possible with the Threaded transport anchor SR - straight tail (page 18).

GENERAL NOTES

The Power System SR is part of the PHILIPP Transport anchor system and complies with the VDI/BV-BS Guideline "Lifting inserts and lifting systems for precast concrete elements" (VDI/BV-BS 6205). The use of the Power System SR requires the compliance with this Installation and Application Instruction as well as the General Installation and Application Instruction.

SYSTEM DESCRIPTION

The Power System SR consists of a cast-in anchor (Threaded transport anchor SR straight tail or Compact anchor SR) and a lifting device (Lifty SR or Lifty SR DS). By means of the lifting device SR, which is screwed to the anchor set in concrete, the precast element is lifted and installed. Both the geometry of the lifting devices SR and the Threaded transport anchors are suitable for any load direction.

THE LOAD CLASS SYSTEM

All components of the Power System SR are classified by load classes. Additionally, the load classes are colour-coded.



COMBINATION

The use of Threaded transport anchors SR strictly requires the application of the corresponding lifting devices SR and recess formers, as otherwise the specified load capacities cannot be achieved!

MATERIALS

The Threaded transport anchors SR are made of a straight reinforcement bar B500B with the straight tail version or of a round steel with foot and a crimped-on insert. All threaded inserts are made of special high precision steel tubes and are galvanized according to common standards. This galvanization protects the anchor temporarily from the storage at the producer site to the final installation in the concrete element.

ELEMENT THICKNESSES, CENTRE AND EDGE DISTANCES

The Installation and position of the Threaded transport anchors SR in precast concrete elements require minimum element thicknesses d as well as minimum centre distances a_a and minimum edge distances a_r (see picture 1 and 2) for a safe load transfer. All values can be found in the corresponding tables.

CONCRETE STRENGTH

At the time of the first lift the concrete must have a minimum strength f_{cc} according to the tables of the different load cases. Given concrete strengths f_{cc} are cube compression strengths at the time of the first lifting.

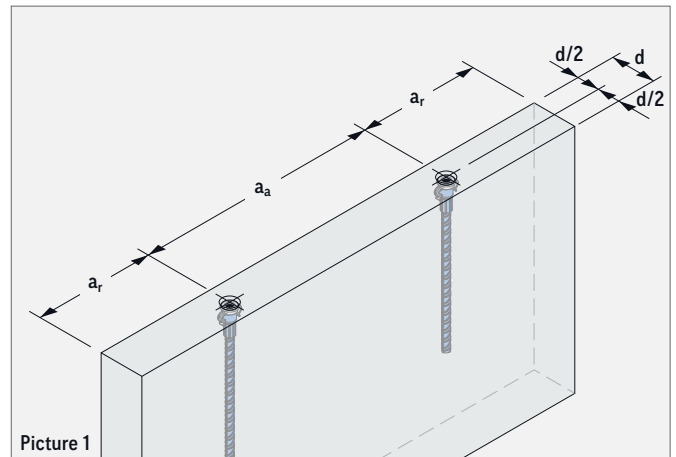

Picture 1

As the Compact anchors SR are installed recessed by using Recess formers SR, the thickness d has to be increased by h_T (picture 2).

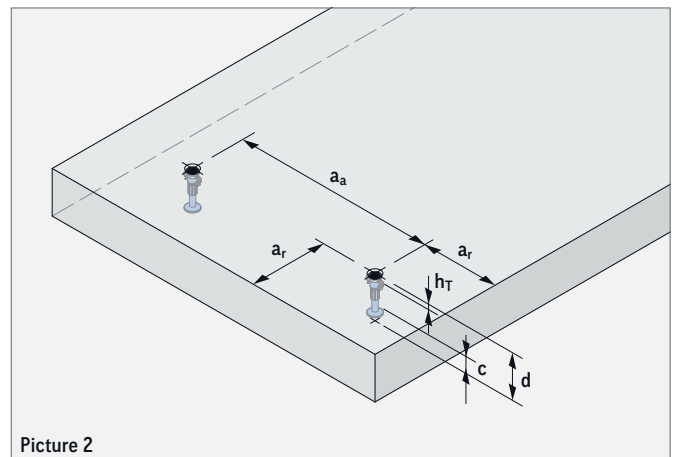

Picture 2

$$c \geq c_{nom} \text{ acc. to EN 1992-1-1}$$



RESISTANCES

All resistances specified in this document apply to normal weight concrete in accordance with EN 206.

REPEATED USE OF TRANSPORT ANCHORS

Threaded transport anchors SR are designed for the transport of precast concrete units only. Multiple use within the transport chain (from production to installation of the unit) means no repeated usage. All Threaded transport anchors SR are not specified for a repeated usage (e.g. ballasts for cranes) or a permanent fixation. Alternatives are stainless steel transport anchors or the PB anchor to fix a construction.

GENERAL NOTES

MARKING

The transport anchors and lifting devices of the Power System SR are marked as follows:

TRANSPORT ANCHOR:

- » Manufacturer
- » CE mark
- » Type (system / thread size)
- » Max. load bearing capacity (e.g. 2500 KG)

LIFTING DEVICE:

- » Manufacturer
- » CE mark
- » Type (system / thread size)
- » Max. load bearing capacity (e.g. 2.5 t)
- » Year of production (backside)

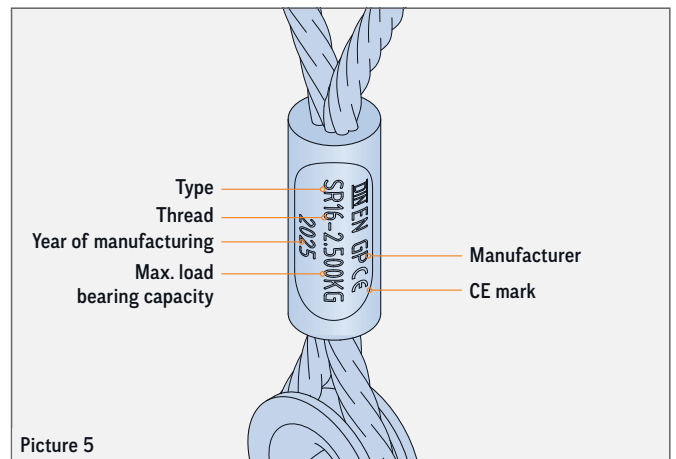
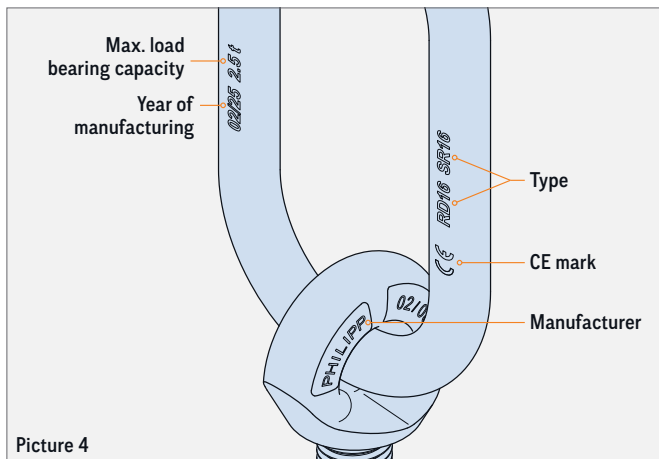
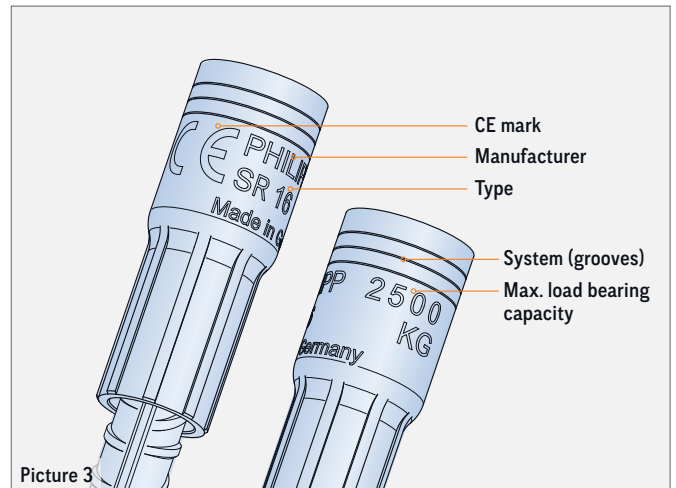

EC DECLARATION OF CONFORMITY

The EC Declaration of Conformity (DoC) of the Power System SR can be downloaded from our website www.philipp-group.de or is available on request.



TABLE 1: DISTINGUISHING FEATURES OF THE SYSTEMS

RD (Right-hand thread)	M (Right-hand thread)	SR (Right-hand thread)	SL (Left-hand thread)
 PHILIPP 1200 RD 16 KG Made in Germany	 PHILIPP 1200 M 16 KG Made in Germany	 PHILIPP 2500 SR 16 KG Made in Germany	 PHILIPP 2000 SL 16 KG Made in Germany

NOTES ON REINFORCEMENT

MINIMUM REINFORCEMENT

In use of the Power System SR precast units must be reinforced with a minimum reinforcement. Depending on the load case this can differ and is specified in the tables of the respective load case. This minimum reinforcement can be replaced by a comparable steel bar reinforcement. The user is personally responsible for further transmission of load into the concrete unit.



REINFORCEMENT

Existing static or constructive reinforcement can be taken into account for the minimum reinforcement of the respective load case.

SINGLE-LAYER REINFORCEMENT

In order to ensure a central anchor position in the element, the mesh reinforcement has to be cut in this area (see picture 6).

REINFORCEMENT INSTRUCTIONS FOR THIN ELEMENTS

In thin elements it might be necessary to cut the longitudinal reinforcement close to the insert (counter brace) in order to have enough concrete cover in this area. Best position for the longitudinal reinforcement should be below the crimping.

ADD. REINFORCEMENT FOR DIAGONAL AND LATERAL TENSION

Additional reinforcement for diagonal and lateral tension has to be installed with pressure contact to the anchor insert. The position of the direct pressure contact must be within the thread reach e of the insert (see picture 8). By using the Marking ring with clip (74KR__CLIPSR) this position is guaranteed.

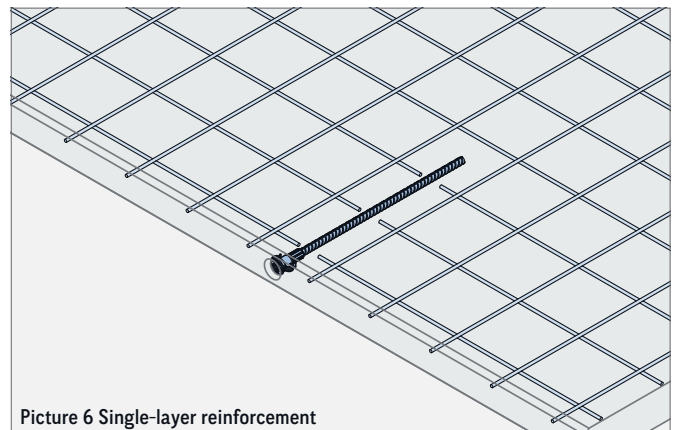

Picture 6 Single-layer reinforcement

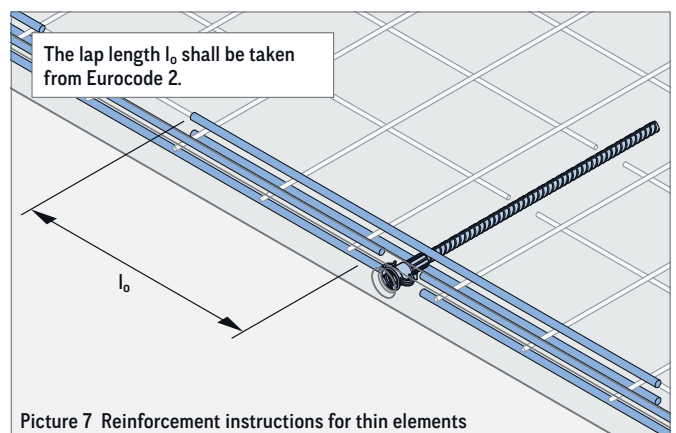

Picture 7 Reinforcement instructions for thin elements

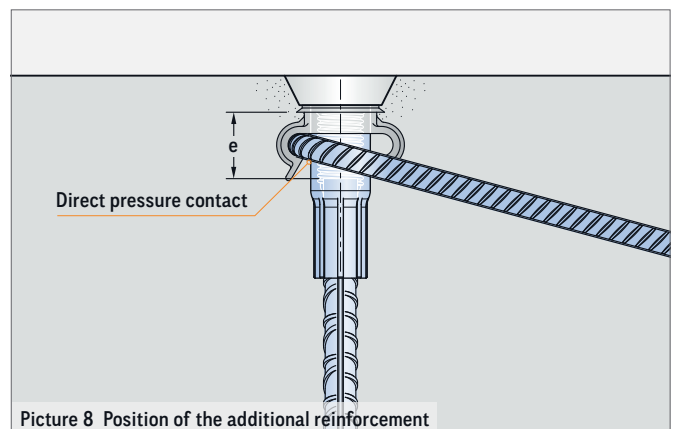

Picture 8 Position of the additional reinforcement

THREADED TRANSPORT ANCHOR SR - STRAIGHT TAIL

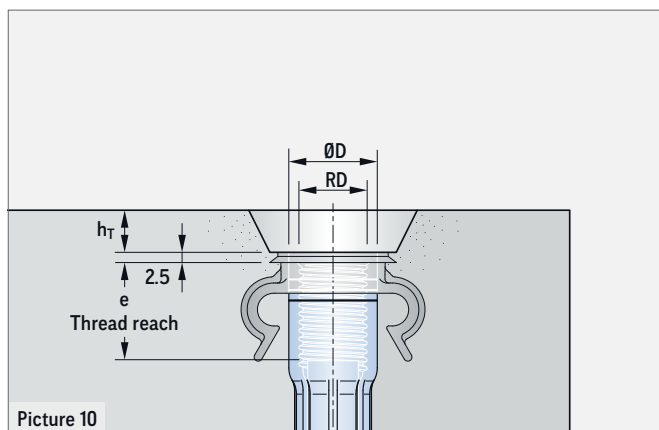
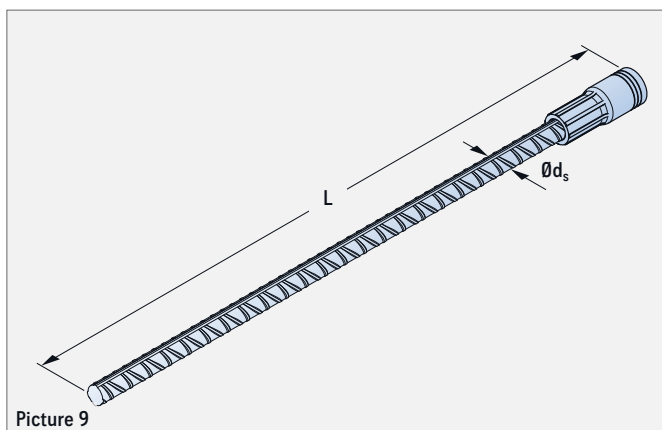

THREADED TRANSPORT ANCHOR SR

The Threaded transport anchor SR – straight tail is used for face-side installation in wall-like elements. It is part of the PHILIPP Transport anchor system and complies with the VDI/BV-BS Guideline "Lifting inserts and lifting systems for precast concrete elements" (VDI/BV-BS 6205).

The use of Transport transport anchors requires the compliance with this Installation and Application Instruction as well as the General Installation and Application Instruction. The anchor may only be used in combination with the mentioned PHILIPP lifting devices of the SR system.

TABLE 2: DIMENSIONS OF THREADED TRANSPORT ANCHOR SR - STRAIGHT TAIL

Ref. no.	Type	Load class	Dimensions					
			RD (mm)	L (mm)	ØD (mm)	Ød _s (mm)	e (mm)	h _T (mm)
67M12SR	SR 12	1.3	12	300	16.0	10	22	10
67M16SR	SR 16	2.5	16	455	21.0	14	27	10
67M20SR	SR 20	4.0	20	480	27.0	18	35	10
67M24SR	SR 24	5.0	24	580	31.0	20	44	10
67M30SR	SR 30	8.0	30	750	39.5	25	49	10
67M36SR	SR 36	10.0	36	800	47.0	28	68	10
67M42SR	SR 42	14.5	42	1100	54.0	32	68	12
67M52SR	SR 52	20.0	52	1200	67.0	40	100	12

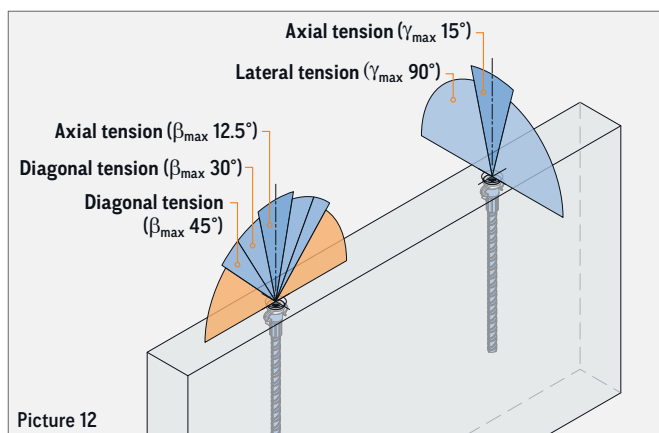
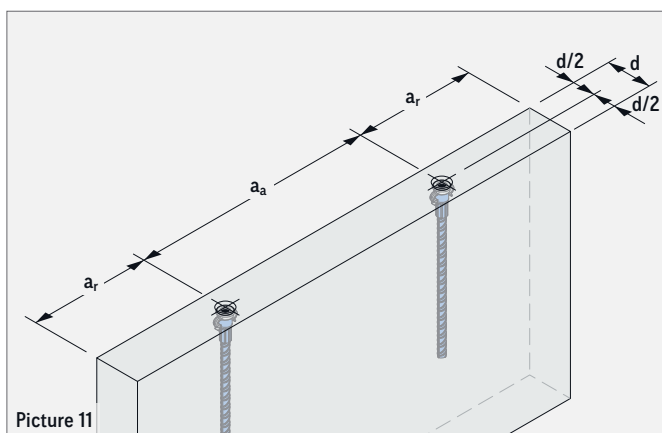

THREADED TRANSPORT ANCHOR SR - STRAIGHT TAIL • WALL-LIKE ELEMENTS • AXIAL TENSION

If the Threaded transport anchor SR is loaded with axial tension $\beta_{\max} 12.5^\circ / \gamma_{\max} 15^\circ$ a reinforcement according to table 3 is required.

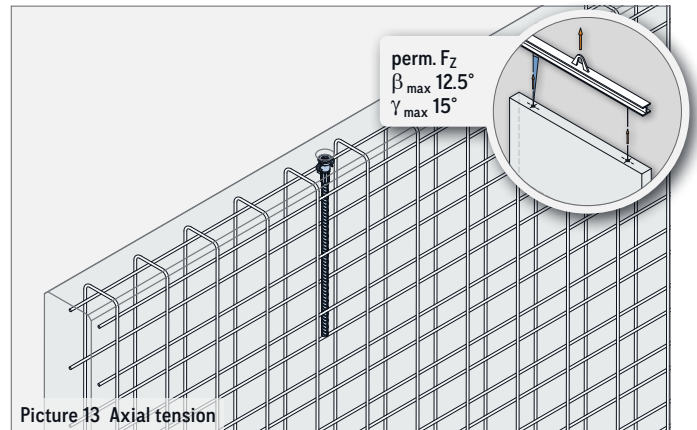

TABLE 3: AXIAL TENSION IF $f_{cc} \geq 15 \text{ N/mm}^2 / 25 \text{ N/mm}^2$

Load class	Min. element thicknesses, min. centre and edge distances			$\beta_{\max} 12.5^\circ / \gamma_{\max} 15^\circ$		
	d (mm)	a_a (mm)	a_r (mm)	perm. F_z		Mesh reinforcement (square) (mm ² /m)
				f_{cc} $\geq 15 \text{ N/mm}^2$ (kN)	f_{cc} $\geq 25 \text{ N/mm}^2$ (kN)	
1.3	80	560	280	8.1	10.4	1 × #188
	100			11.0	13.0	2 × #188 ②
	120			13.0	13.0	2 × #188 ②
2.5	80	930	465	19.8	25.0	1 × #188
	100			25.0	25.0	2 × #188 ②
4.0	80	960	480	22.6	29.1	1 × #188
	100			30.9	39.9	1 × #188
	120			38.9	40.0	2 × #188 ②
	140			40.0	40.0	2 × #188 ②
5.0	100	1180	590	40.8	50.0	2 × #188 ②
	120			50.0	50.0	2 × #188 ②
8.0	120	1520	760	80.0	80.0	2 × #188
10.0	140	1600	800	89.9	100.0	2 × #188 ②
	160			96.2		
	180			100.0		
14.5 ①	160	2230	1115	145.0	145.0	2 × #188 ②
20.0	200	2430	1215	181.7	200.0	2 × #257 ②

The weight of 1.0 t corresponds to 10.0 kN.

① When using the Lifty SR DS (page 43) the maximum load capacity is reduced to 125 kN (12.5 t).

② The reinforcement shall be formed as a double-bended mesh reinforcement or with equivalent stirrups.

THREADED TRANSPORT ANCHOR SR - STRAIGHT TAIL • WALL-LIKE ELEMENTS • DIAGONAL TENSION

If the Threaded transport anchor SR is loaded with diagonal tension $\beta > 12.5^\circ$ an additional reinforcement according to table 4 is required.

Here the reinforcement for diagonal tension is placed contrarily to the tensile direction (picture 14) and must have direct pressure contact to the anchor insert in the peak of its bending. The installation of the reinforcement for diagonal tension can be done in an angle of 0° up to 20° to the concrete surface.

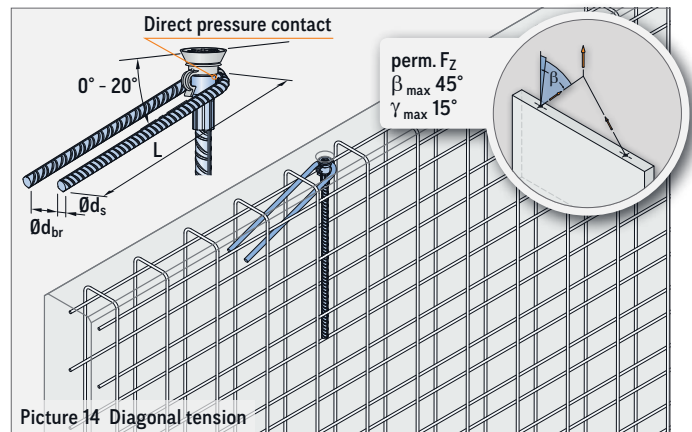

TABLE 4: DIAGONAL TENSION IF $f_{cc} \geq 15 \text{ N/mm}^2 / 25 \text{ N/mm}^2$

Load class	Min. element thicknesses, min. centre and edge distances			$\beta_{\max} 30^\circ / \gamma_{\max} 15^\circ$						$\beta_{\max} 45^\circ / \gamma_{\max} 15^\circ$					
				perm. F_z		Additional reinforcement for diagonal tension				perm. F_z		Additional reinforcement for diagonal tension			
				f_{cc} $\geq 15 \text{ N/mm}^2$	f_{cc} $\geq 25 \text{ N/mm}^2$	Mesh rein- forcement (square)	Reinforcement for diagonal tension (B500B)	f_{cc} $\geq 15 \text{ N/mm}^2$	f_{cc} $\geq 25 \text{ N/mm}^2$	Mesh rein- forcement (square)	Reinforcement for diagonal tension (B500B)				
d (mm)	a_a (mm)	a_r (mm)	(kN)	(kN)	(mm ² /m)	$\emptyset d_s$ (mm)	L (mm)	$\emptyset d_{br}$ (mm)	(kN)	(kN)	(mm ² /m)	$\emptyset d_s$ (mm)	L (mm)	$\emptyset d_{br}$ (mm)	
1.3	80	560	280	7.5	8.4	1 × #188	8	250	24	7.5	8.4	1 × #188	8	250	24
	100			8.4		2 × #188 ②				8.4		2 × #188 ②			
2.5	80	930	465	16.2	17.7	1 × #188	10	350	24	16.2	17.7	1 × #188	10	350	24
	100			16.3		2 × #188 ②				16.3		2 × #188 ②			
	120			16.5		2 × #188 ②				16.5		2 × #188 ②			
4.0	80	960	480	14.7	18.9	1 × #188	12	470	34	14.7	18.9	1 × #188	12	470	34
	100			20.8		2 × #188 ②				20.8		2 × #188 ②			
	120			28.0		2 × #188 ②				28.0		2 × #188 ②			
	140			29.9		2 × #188 ②				29.9		2 × #188 ②			
5.0	100	1180	590	42.5	42.5	2 × #188 ②	12	550	34	42.5	42.5	2 × #188 ②	12	550	34
	120			42.5		2 × #188 ②				42.5		2 × #188 ②			
8.0	120	1520	760	61.5	66.4	2 × #188 ②	16	700	41	61.5	66.4	2 × #188 ②	16	700	41
	140			64.5		2 × #188 ②				64.5		2 × #188 ②			
	160			66.4		2 × #188 ②				66.4		2 × #188 ②			
10.0	140	1600	800	52.7	68.0	2 × #188 ②	20	800	64	52.7	68.0	2 × #188 ②	20	800	64
	160			66.2		2 × #188 ②				66.2		2 × #188 ②			
	180			77.5		2 × #188 ②				77.5		2 × #188 ②			
14.5 ①	160	2230	1115	116.0	116.0	2 × #188 ②	20	1000	64	116.0	116.0	2 × #188 ②	20	1000	64
20.0	200	2430	1215	148.4	191.6	2 × #257 ②	20	1000	100	104.9	135.5	2 × #257 ②	20	1000	140

The weight of 1.0 t corresponds to 10.0 kN.

① When using the Lifty SR DS (page 43) the maximum load capacity is reduced to 125 kN (12.5 t).

② The reinforcement shall be formed as a double-bended mesh reinforcement or with equivalent stirrups.

THREADED TRANSPORT ANCHOR SR - STRAIGHT TAIL • WALL-LIKE ELEMENTS • LATERAL TENSION

If a Threaded transport anchor SR is loaded with lateral tension $\gamma \geq 15^\circ$ an additional reinforcement according to table 5 is required. This reinforcement for lateral tension shall be installed face-sided of the wall contrarily to the load direction. Tilting of walls can cause diagonal and lateral tension at the same time, so-called diagonal-lateral-tension, to the transport anchors (picture 16). In this case only the reinforcement for lateral tension is required (double reinforcement bar). The diagonal tension is already covered by using this reinforcement. During mounting the tilt-up or turn-over of a unit requires lateral reinforcement (single reinforcement bar according to picture 15). The double reinforcement bar (picture 16) covers all load directions. In addition to the mesh reinforcement (in double-bended form) a longitudinal reinforcement shall be installed as shown in table 5.

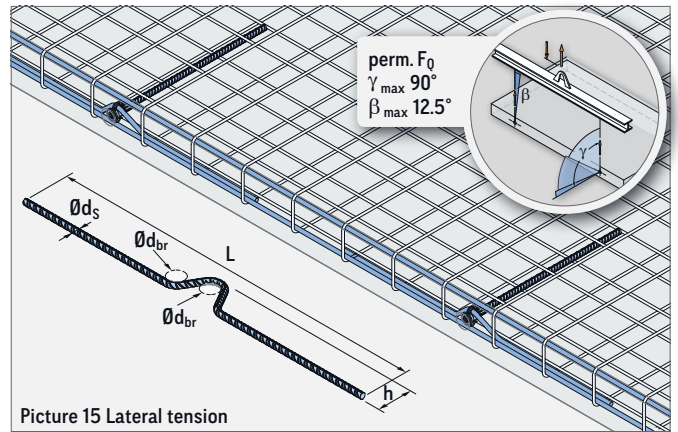

Picture 15 Lateral tension

The planner has the option to design the reinforcement for lateral tension either as a single reinforcement bar (picture 15) or as double reinforcement bar (picture 16). Nevertheless, there must be direct pressure contact between the insert of the transport anchor and the reinforcement in the peak of the bending.

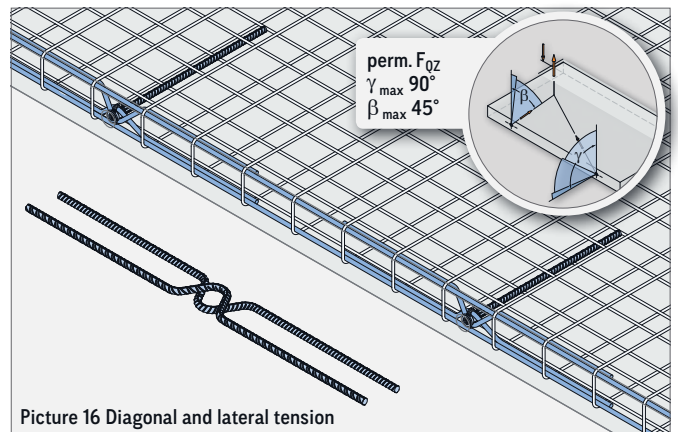

Picture 16 Diagonal and lateral tension

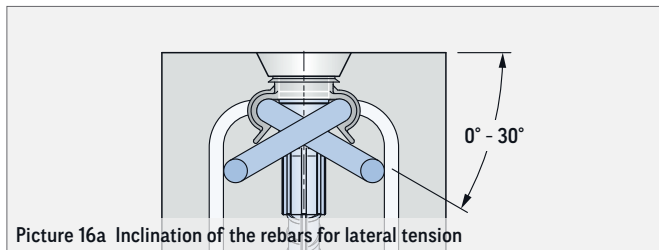

Picture 16a Inclination of the rebars for lateral tension

THREADED TRANSPORT ANCHOR SR - STRAIGHT TAIL • WALL-LIKE ELEMENTS • LATERAL TENSION

TABLE 5: LATERAL TENSION IF $f_{cc} \geq 15 \text{ N/mm}^2 / 25 \text{ N/mm}^2$

Load class	Min. element thicknesses, min. centre and edge dis- tances			$\beta_{\max} 90^\circ / \gamma_{\max} 45^\circ$							
				perm. F_z		Mesh reinforcement (square)	Additional reinforcement for lateral tension				
				f_{cc} $\geq 15 \text{ N/mm}^2$	f_{cc} $\geq 25 \text{ N/mm}^2$		Single rebar for lateral tension (B500B)		Longitudinal rein- forcement (B500B)		
d (mm)	a_a (mm)	a_r (mm)	(kN)	(kN)	(mm ² /m)	$\emptyset d_{s1}$ (mm)	L_1 (mm)	h_1 (mm)		$\emptyset d_{br1}$ (mm)	Quantity $\times \emptyset$ / Length (mm)
1.3	80	560	280	3.7	4.8	1 × #188	8	550	33	30	2 × Ø10 / 930
	100			5.5	6.0	2 × #188 ②			43		
	120			6.0	6.0	2 × #188 ②			53		
2.5	80	930	465	5.6	7.3	1 × #188	10	800	40	32	2 × Ø10 / 930
	100			7.9	10.2	2 × #188 ②			50		
	120			10.5	12.5	2 × #188 ②			60		
4.0	80	960	480	6.4	8.3	1 × #188	12	910	42	48	2 × Ø10 / 960
	100			9.0	11.6	2 × #188 ②			52		
	120			11.9	15.6				62		
	140			15.6	19.6				72		
	160			19.4	19.6				82		
5.0	100	1180	590	10.6	13.7	2 × #188 ②	12	1000	57	48	2 × Ø12 / 1180
	120			13.8	17.8				67		
	140			17.5	22.6				77		
	160			21.6	27.9				87		
8.0	120	1520	760	15.9	20.5	2 × #188 ②	16	1200	76	48	2 × Ø14 / 1520
	140			20.3	26.2				86		
	160			25.1	32.4				96		
	180			30.3	39.2				106		
10.0	140	1600	800	18.6	23.5	2 × #188 ②	20	1690	88	64	2 × Ø14 / 1600
	160			22.7	29.2				98		
	180			27.5	35.5				108		
	200			32.8	42.4				118		
14.5	160	2230	1115	27.4	35.3	2 × #188 ②	20	1800	107	64	2 × Ø14 / 2230
	180			33.1	42.7				117		
	200			39.6	51.1				127		
	220			46.3	59.8				137		
20.0	240	2430	1215	53.8	69.4	2 × #257 ②	20	1800	147	140	2 × Ø14 / 2430

The weight of 1.0 t corresponds to 10.0 kN.

② The reinforcement shall be formed as a double-bended mesh reinforcement or with equivalent stirrups.

THREADED TRANSPORT ANCHOR SR - STRAIGHT TAIL • WALL-LIKE ELEMENTS • INCLINED INSTALLATION

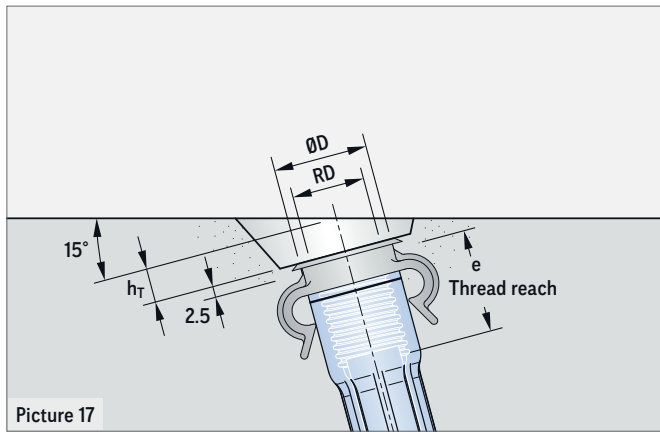

Picture 17

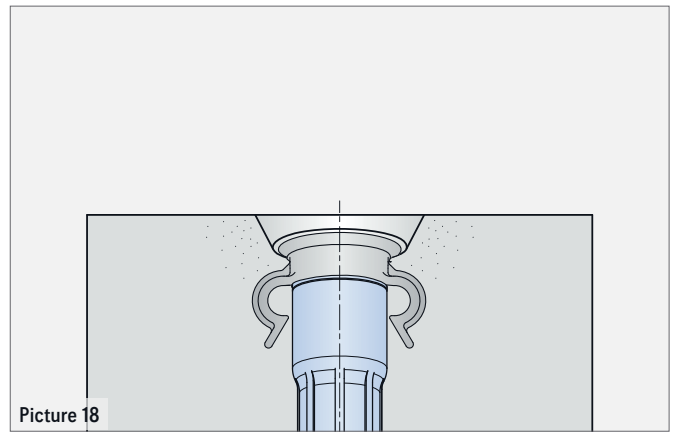

Picture 18

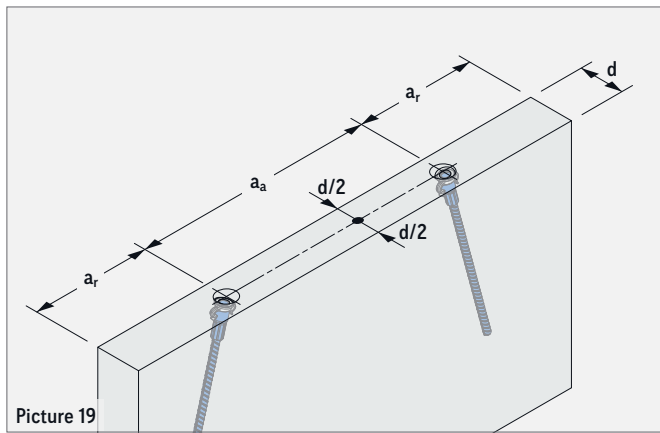

Picture 19

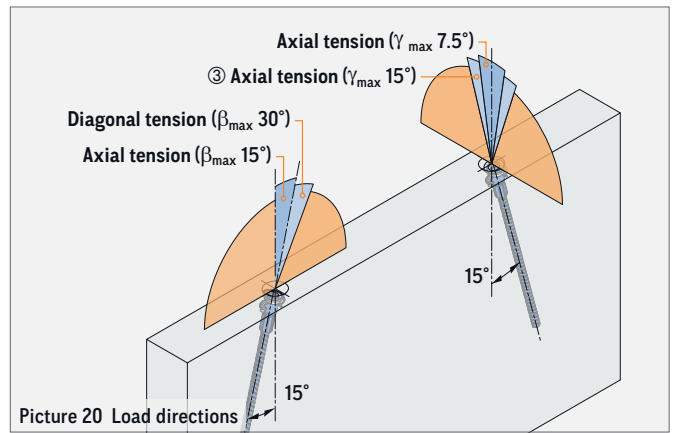

Picture 20 Load directions

ⓐ Only possible when using a tilting table!

THREADED TRANSPORT ANCHOR SR (INCLINED INSTALLATION)

Due to the 15° inclined installation of the Threaded transport anchor an axial load as well as a diagonal load direction $\beta_{\max} 30^\circ$ is possible. Basically, a lateral load on the anchors up to $\gamma_{\max} 7.5^\circ$ during transport of the elements is allowed. If an element is produced on a tilting table an angle up to $\gamma_{\max} 15^\circ$ is possible.

MINIMUM REINFORCEMENT

In use of Threaded transport anchors SR precast units must be reinforced with a minimum reinforcement according to table 6. This minimum reinforcement can be replaced by comparable reinforcing bars. The user is personally responsible for further transmission of load into the concrete unit.

SINGLE-LAYER REINFORCEMENT

In order to ensure a central position of the anchor in the element, the mesh reinforcement has to be installed asymmetrically in the element in case of a single-layer reinforcement (see picture 21).

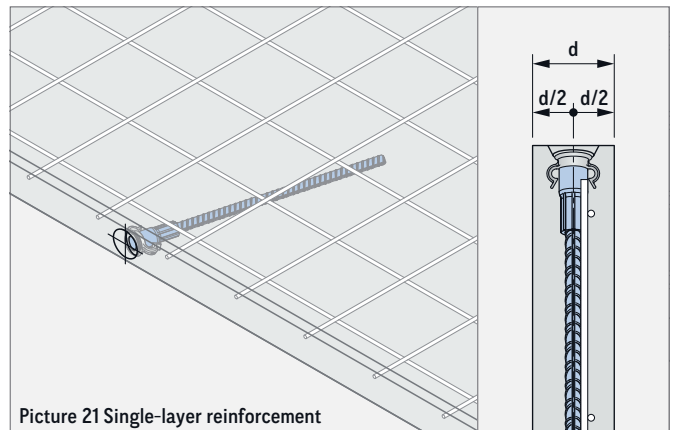

Picture 21 Single-layer reinforcement



EXISTING REINFORCEMENT

Existing static or constructive reinforcement can be taken into account for the minimum reinforcement for the respective load case.

THREADED TRANSPORT ANCHOR SR - STRAIGHT TAIL • WALL-LIKE ELEMENTS • INCLINED INSTALLATION (SZ15)

AXIAL TENSION/ DIAGONAL TENSION

If the Threaded transport anchor SR is loaded with axial or diagonal tension $\beta > 30^\circ$ an additional reinforcement according to table 6 is required.

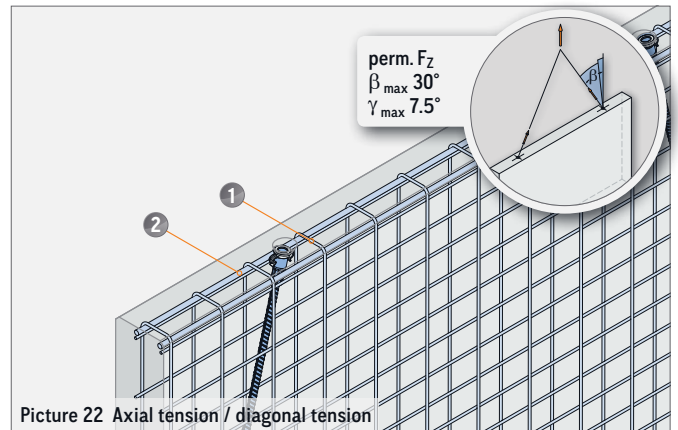

Picture 22 Axial tension / diagonal tension

LATERAL TENSION

A lateral load on the anchors above $\gamma_{max} 7.5^\circ$ is not allowed during transport! If the element is produced on a tilting table an angle up to $\gamma_{max} 15^\circ$ is possible. Also a diagonal load direction with an angle $\beta > 30^\circ$ is not allowed!

TABLE 6: AXIAL AND DIAGONAL TENSION WITH $f_{cc} \geq 15 \text{ N/mm}^2$ UP TO 27.5 N/mm^2

Load class	Min. element thicknesses min. centre and edge distances			$\beta_{max} 30^\circ / \gamma_{max} 7.5^\circ$ ③						① Mesh reinforcement (square)	② Longitudinal reinforcement (B500B) Quantity × Ø / length (mm)
	d	a _a	a _r	perm. F _Z							
				$f_{cc} \geq 15 \text{ N/mm}^2$	$f_{cc} \geq 17.5 \text{ N/mm}^2$	$f_{cc} \geq 20 \text{ N/mm}^2$	$f_{cc} \geq 22.5 \text{ N/mm}^2$	$f_{cc} \geq 25 \text{ N/mm}^2$	$f_{cc} \geq 27.5 \text{ N/mm}^2$		
(mm)	(mm)	(mm)	(kN)	(kN)	(kN)	(kN)	(kN)	(kN)	(mm ² /m)		
1.3	60	400	200	9.1	9.8	10.5	10.5	10.5	10.5	1 × #188	-
2.5	100	600	300	24.2	24.2	24.2	24.2	24.2	24.2	2 × #188 ②	-
4.0	120	700	350	38.6	40.0	40.0	40.0	40.0	40.0	2 × #188 ②	-
5.0	120	700	350	38.6	41.7	44.6	44.6	44.6	44.6	2 × #188 ②	-
8.0	120	900	450	60.5	65.4	69.9	73.0	73.0	73.0	2 × #188 ②	-
10.0	140	1100	550	70.1	75.8	78.1	78.1	78.1	78.1	2 × #188 ②	-
				70.1	75.8	81.0	85.9	85.9	85.9	2 × #257 ②	-
① 14.5	150	1200	600	-	86.9	92.9	95.0	95.0	95.0	2 × #188 ②	-
				132.0	139.6	139.6	139.6	139.6	139.6	2 × #257 ②	2 × Ø10 / 1100
20.0	200	1600	800	-	-	175.0	185.7	186.9	186.9	2 × #257 ②	-
				-	-	175.0	185.7	195.7	200.0	2 × #335 ②	-

① When using the Lifty SR DS (page 43) the maximum load capacity is reduced to 125 kN (12.5 t).

② The reinforcement shall be formed as a double-bended mesh reinforcement or with equivalent stirrups.

③ If a tilting table is used an angle of $\gamma_{max} 15^\circ$ is possible!

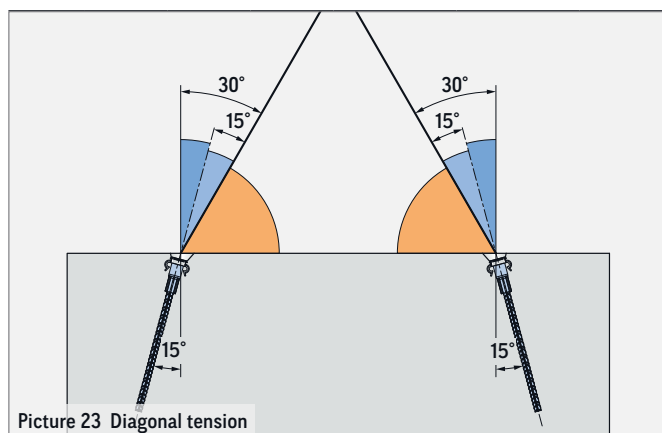

Picture 23 Diagonal tension

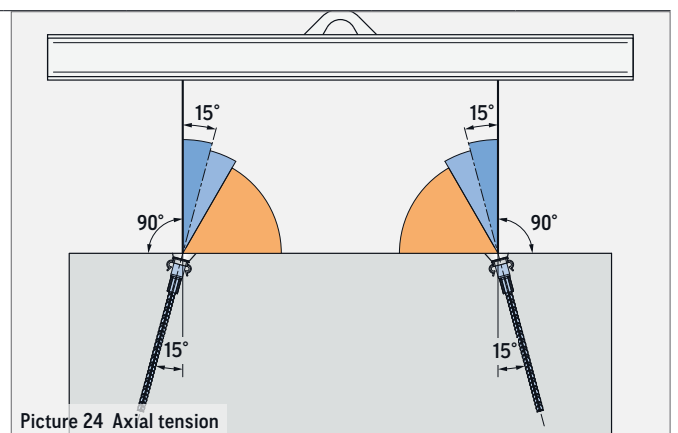

Picture 24 Axial tension

THREADED TRANSPORT ANCHOR SR - STRAIGHT TAIL • WALL-LIKE ELEMENTS • INCLINED INSTALLATION (SZ15)

INSTALLATION OF THE SYSTEM

The Recess former SZ15 is fixed to the formwork at the intended position. Here, the marking of the tensile direction (later load direction of the anchors) has to be followed. This must point in the direction of the wall centre (centre of gravity, picture 26). For an exact positioning, the notches at the edge of the recess former are used (picture 27). A precise positioning on the formwork is necessary, as otherwise e.g. a twisting of the recess former will lead to a misalignment of the anchor and thus the full load-bearing

capacity is not given anymore (picture 28). Now the Threaded transport anchor SR can be screwed onto the fixed recess former. Depending on the length of the Threaded transport anchor, it may be necessary to fix it additionally to the reinforcement of the concrete element. After the demoulding, the steel recess former can be quickly and easily removed with an Allen key (HEX see table 19).

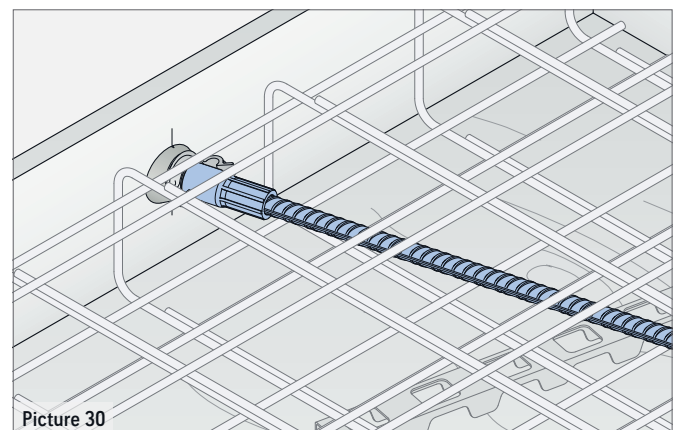
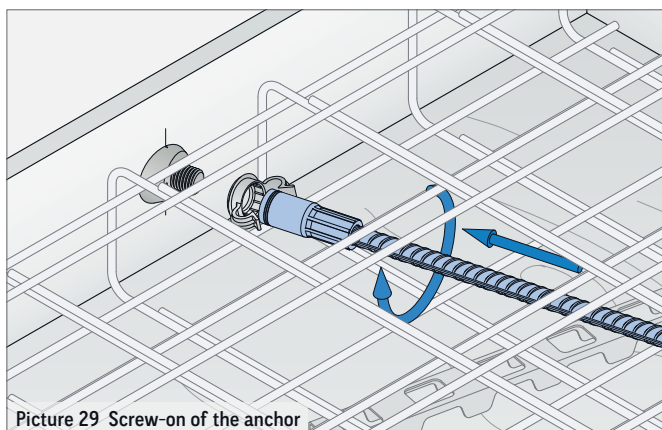
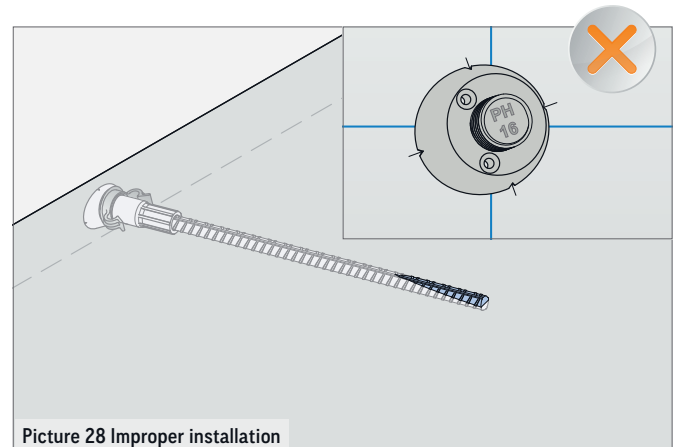
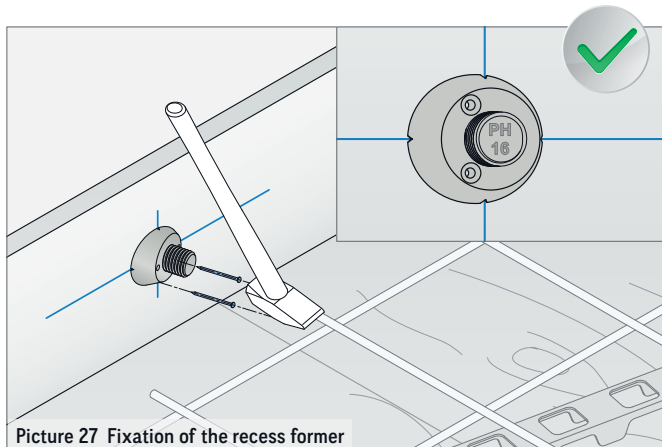
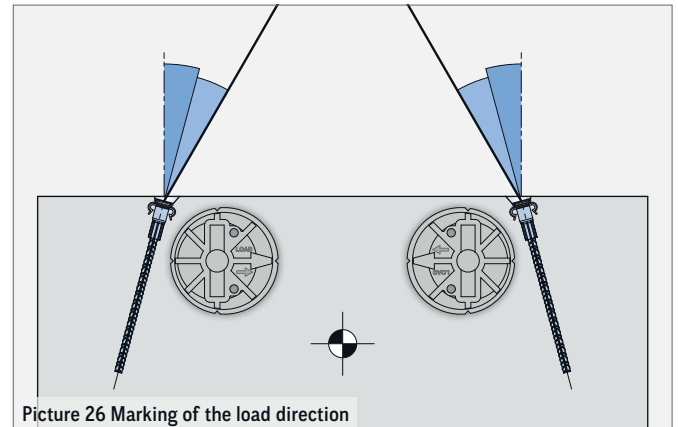
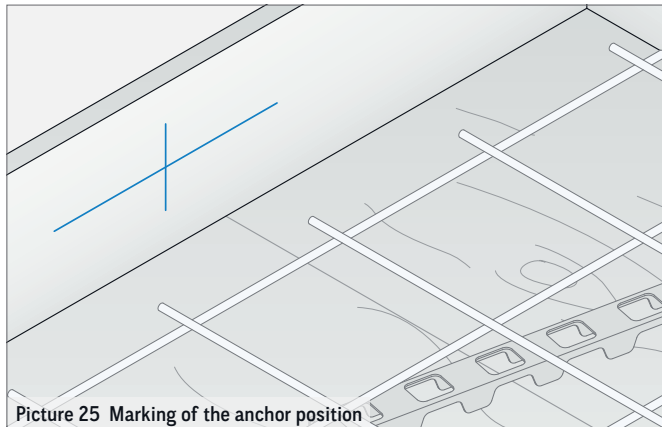

COMPACT ANCHOR SR

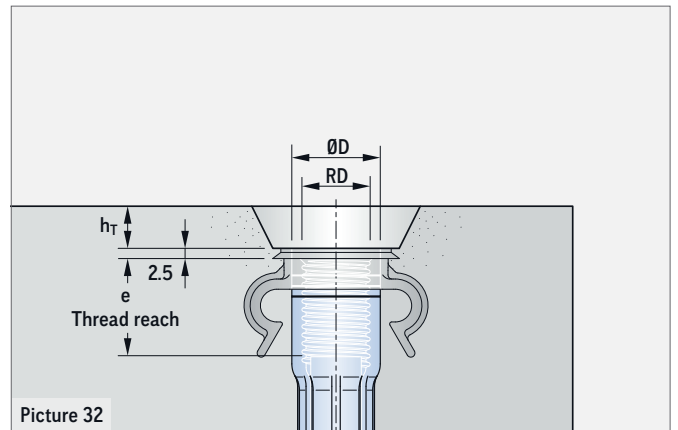
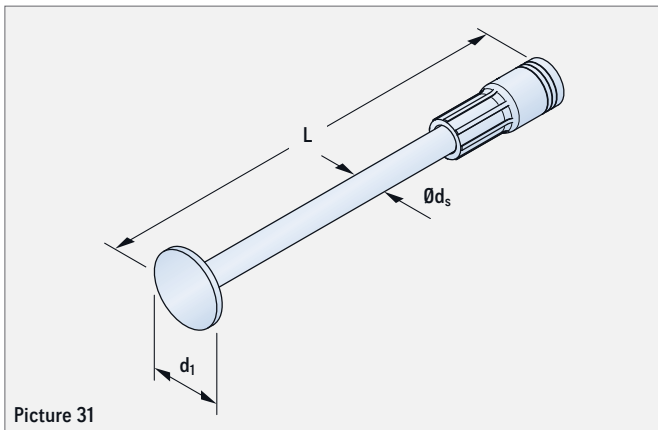

COMPACT ANCHOR SR

The Compact anchor SR is used for face-side installation in wall and beam-like elements as well as stairs. It is part of the PHILIPP Transport anchor system and complies with the VDI/BV-BS Guideline "Lifting inserts and lifting systems for precast concrete elements" (VDI/BV-BS 6205).

The use of Transport anchors requires the compliance with this Installation and Application Instruction as well as the General Installation and Application Instruction. The anchor may only be used in combination with the mentioned PHILIPP lifting devices of the SR system.

TABLE 7: DIMENSIONS OF THE COMPACT ANCHOR SR

Ref. no.	Type	Load class	Dimensions						
			RD (mm)	L (mm)	ØD (mm)	Ød _s (mm)	e (mm)	h _T (mm)	d ₁ (mm)
67K120130SR	SR 12	1.3	12	130	16.0	9.0	22	10	25
67K160200SR	SR 16	2.5	16	200	21.0	12.5	27	10	35
67K200258SR	SR 20	4.0	20	258	27.0	16.5	35	10	45
67K240325SR	SR 24	5.0	24	325	31.0	18.5	44	10	50
67K300400SR	SR 30	8.0	30	400	39.5	22.0	49	10	60
67K360475SR	SR 36	10.0	36	475	47.0	27.0	68	10	70
67K420550SR	SR 42	14.5	42	550	54.0	30.5	65	12	85

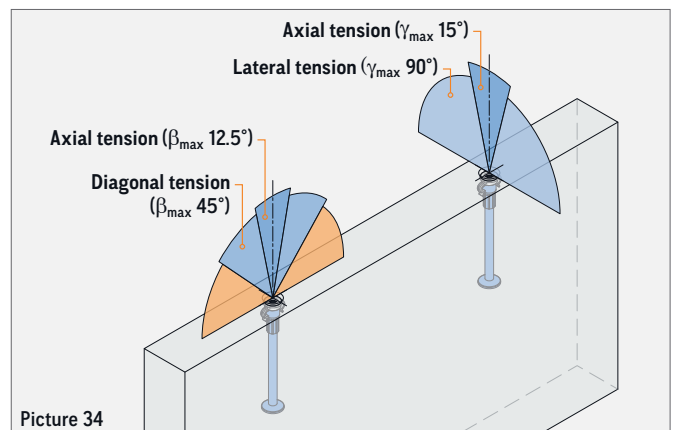
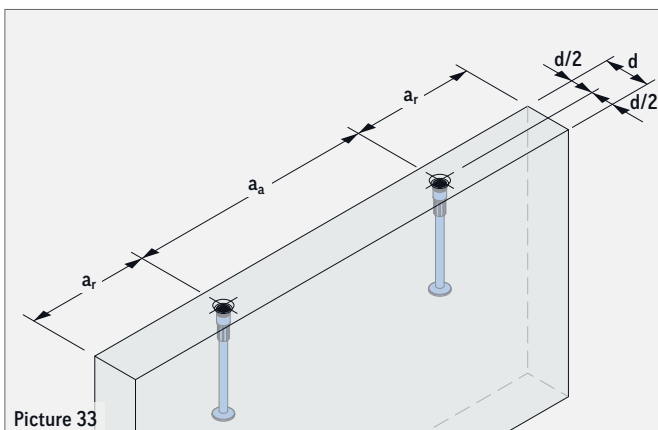

COMPACT ANCHOR SR • WALL-LIKE ELEMENTS • AXIAL TENSION

If the Compact anchor SR is loaded with axial tension $\beta_{\max} 12.5^\circ / \gamma_{\max} 15^\circ$ an additional reinforcement according to table 8 is required.

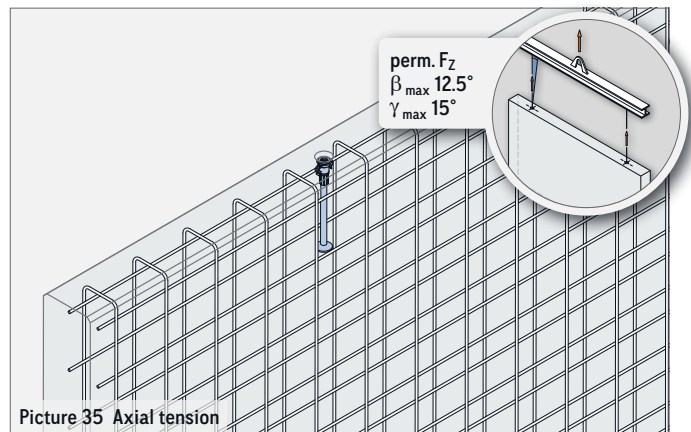

TABLE 8: AXIAL TENSION IF $f_{cc} \geq 15 \text{ N/mm}^2 / 25 \text{ N/mm}^2$

Load class	Min. element thicknesses, min. centre and edge distances			$\beta_{\max} 12.5^\circ / \gamma_{\max} 15^\circ$		Mesh reinforcement (square) (mm ² /m)
	d (mm)	a _a (mm)	a _r (mm)	f _{cc} ≥ 15 N/mm ² (kN)	f _{cc} ≥ 25 N/mm ² (kN)	
1.3	80	560	280	8.4	10.8	1 × #188
	100			11.9	13.0	2 × #188 ②
	120			13.0	13.0	2 × #188 ②
2.5	80	930	465	13.1	16.9	1 × #188
	100			18.6	24.0	2 × #188 ②
	120			25.0	25.0	2 × #188 ②
4.0	80	960	480	16.3	21.0	1 × #188
	100			23.2	29.9	2 × #188 ②
	120			31.1	40.0	
	140			39.7		
	160			40.0		
5.0	120	1180	590	35.4	45.7	2 × #188 ②
	140			45.1	50.0	
	160			50.0	50.0	
8.0	140	1520	760	52.5	67.7	2 × #188 ②
	160			65.9	80.0	
	180			75.9	80.0	
10.0	160	1600	800	73.8	94.9	2 × #188 ②
	180			90.1	100.0	
	200			98.2		
	220			99.3		
	240			99.3		
14.5 ①	180	2230	1115	116.6	133.5	2 × #188 ②
	200			118.4		
	220			119.6		
	240			120.8		

The weight of 1.0 t corresponds to 10.0 kN.

① When using the Lifty SR DS (page 43) the maximum load capacity is reduced to 125 kN (12.5 t).

② The reinforcement shall be formed as a double-banded mesh reinforcement or with equivalent stirrups.

COMPACT ANCHOR SR • WALL-LIKE ELEMENTS • DIAGONAL TENSION

If the Compact anchor SR is loaded with diagonal tension $\beta > 12.5^\circ$ an additional reinforcement according to table 9 is required. Here the reinforcement for diagonal tension is placed contrarily to the tensile direction (picture 36) and must have direct pressure contact to the anchor insert in the peak of its bending. The installation of the rebars for diagonal tension can be done in an angle of 0° up to 20° to the concrete surface. In case of an installation angle of 0° the transport anchor has to be installed in a recessed position (e.g. by using a recess former) to ensure the minimum required concrete cover.

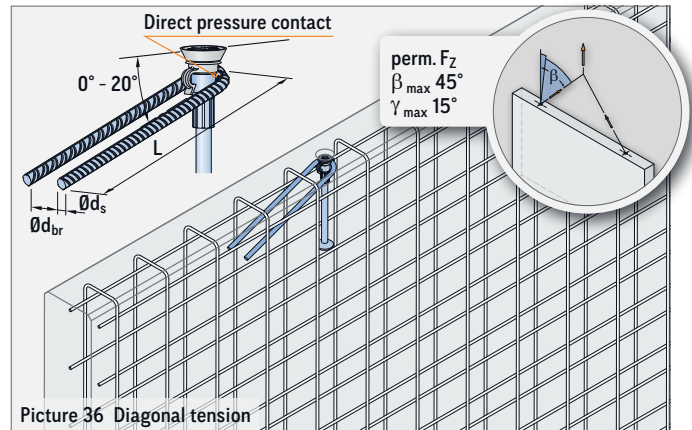

TABLE 9: DIAGONAL TENSION IF $f_{cc} \geq 15 \text{ N/mm}^2 / 25 \text{ N/mm}^2$

Load class	Min. element thicknesses, min. centre distances and min. edge distances			$\beta_{\max} 45^\circ / \gamma_{\max} 15^\circ$					
				perm. F_Z		Additional reinforcement for diagonal tension			
				$f_{cc} \geq 15 \text{ N/mm}^2$ (kN)	$f_{cc} \geq 25 \text{ N/mm}^2$ (kN)	Mesh reinforcement (square) (mm ² /m)	Reinforcement for diagonal tension (B500B)		
d (mm)	a_a (mm)	a_r (mm)				θ_{ds} (mm)	L (mm)	θ_{dbr} (mm)	
1.3	80	560	280	7.5	8.4	1 × #188	8	250	24
	100			8.4		2 × #188 ②			
2.5	80	930	465	11.8	15.2	1 × #188	10	350	24
	100			16.8		2 × #188 ②			
	120			17.7					
4.0	80	960	480	14.7	18.9	1 × #188	12	470	34
	100			20.8		2 × #188 ②			
	120			28.0					
	140			29.9					
5.0	120	1180	590	31.9	41.2	2 × #188 ②	12	550	34
	140			40.6					
	160			42.5					
8.0	140	1520	760	47.2	61.0	2 × #188 ②	16	700	41
	160			59.3					
	180			66.4					
10.0	160	1600	800	66.2	77.5	2 × #188 ②	20	800	64
	180			77.5					
14.5 ①	180	2230	1115	105.0	116.0	2 × #188 ②	20	1000	64
	200			106.6					
	220			107.6					
	240			108.7					

The weight of 1.0 t corresponds to 10.0 kN.

① When using the Lifty SR DS (page 43) the maximum load capacity is reduced to 125 kN (12.5 t).

② The reinforcement shall be formed as a double-bended mesh reinforcement or with equivalent stirrups.

COMPACT ANCHOR SR • WALL-LIKE ELEMENTS • LATERAL TENSION

If a Compact anchor SR is loaded with lateral tension $\gamma \geq 15^\circ$ an additional reinforcement according to table 10 is required. This reinforcement for lateral tension shall be installed face-sided of the wall contrarily to the load direction. Tilting of walls can cause diagonal and lateral tension at the same time, so called diagonal-lateral-tension, to the transport anchors (picture 38). In this case only the reinforcement for lateral tension is required (double reinforcement bar). The diagonal tension is already covered by using this reinforcement. During mounting the tilt-up or turn-over of a unit requires lateral reinforcement (single reinforcement bar according to picture 37). The double reinforcement bar (picture 38) covers all load directions. In addition to the mesh reinforcement (in double-bended form) longitudinal reinforcement shall be installed as shown in table 10.

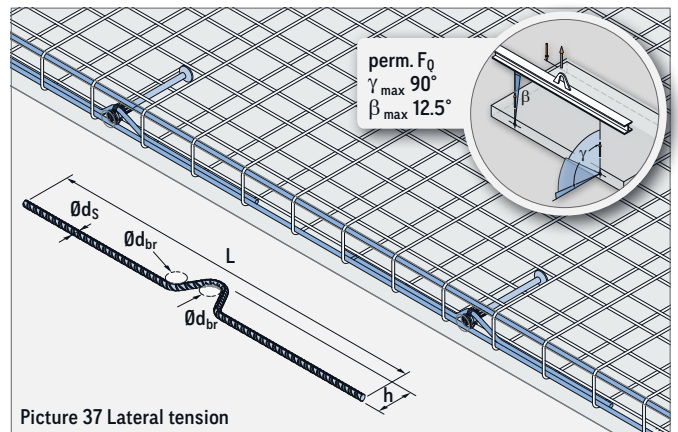

Picture 37 Lateral tension

The planner has the option to design the reinforcement for lateral tension either as a single reinforcement bar (picture 37) or as double reinforcement bar (picture 38). Nevertheless, there must be direct pressure contact between the insert of the transport anchor and the reinforcement in the peak of the bending.

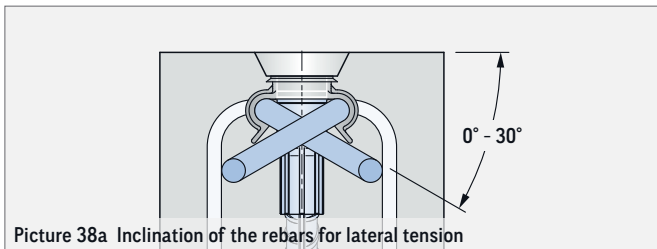

Picture 38a Inclination of the rebars for lateral tension

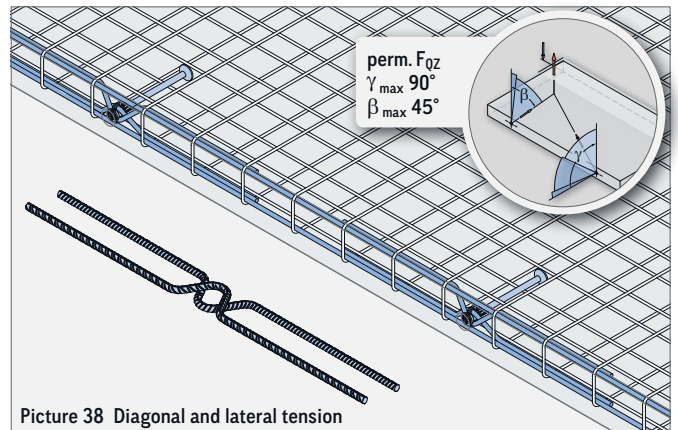

Picture 38 Diagonal and lateral tension

COMPACT ANCHOR SR • WALL-LIKE ELEMENTS • LATERAL TENSION

TABLE 10: LATERAL TENSION IF $f_{cc} \geq 15 \text{ N/mm}^2 / 25 \text{ N/mm}^2$

Load class	Min. element thicknesses, min. centre and edge dis- tances			$\beta_{\max} 90^\circ / \gamma_{\max} 45^\circ$							
				perm. F_z		Mesh reinforcement (square)	Additional reinforcement for lateral tension				
				f_{cc} $\geq 15 \text{ N/mm}^2$	f_{cc} $\geq 25 \text{ N/mm}^2$		Single rebar for lateral tension (B500B)			Longitudinal reinforcement (B500B)	
d (mm)	a_a (mm)	a_r (mm)	(kN)	(kN)	(mm ² /m)	$\emptyset d_s$ (mm)	L (mm)	h (mm)	$\emptyset d_{br}$ (mm)	Quantity $\times \emptyset$ / length (mm)	
1.3	80	560	280	3.7	4.8	1 \times #188	8	550	33	30	2 \times $\emptyset 10$ / 930
	100			5.5	6.0	2 \times #188 ②			43		
	120			6.0		53					
2.5	80	930	465	5.6	7.3	1 \times #188	10	800	40	32	2 \times $\emptyset 10$ / 930
	100			7.9	10.2	2 \times #188 ②			50		
	120			10.5	12.5	60					
4.0	80	960	480	6.4	8.3	1 \times #188	12	910	42	48	2 \times $\emptyset 10$ / 960
	100			9.0	11.6	2 \times #188 ②			52		
	120			11.9	15.4				62		
	140			15.6	19.6				72		
	160			19.4					82		
5.0	120	1180	590	14.8	19.1	2 \times #188 ②	12	1000	67	48	2 \times $\emptyset 12$ / 1180
	140			19.4	25.0				77		
	160			24.1	30.1				87		
8.0	140	1520	760	19.5	25.1	2 \times #188 ②	16	1200	86	48	2 \times $\emptyset 14$ / 1520
	160			24.2	31.2				96		
	180			29.4	37.9				106		
	200			35.1	45.3				116		
10.0	160	1600	800	22.7	29.2	2 \times #188 ②	20	1690	98	64	2 \times $\emptyset 14$ / 1600
	180			27.5	35.5				108		
	200			32.8	42.4				118		
	220			39.2	50.7				128		
14.5	180	2230	1115	31.5	40.6	2 \times #188 ②	20	1800	117	64	2 \times $\emptyset 14$ / 2230
	200			37.5	48.5				127		
	220			44.9	57.9				137		
	240			52.0	67.2				147		

The weight of 1.0 t corresponds to 10.0 kN.

② The reinforcement shall be formed as a double-bended mesh reinforcement or with equivalent stirrups.

COMPACT ANCHOR SR - SHORT

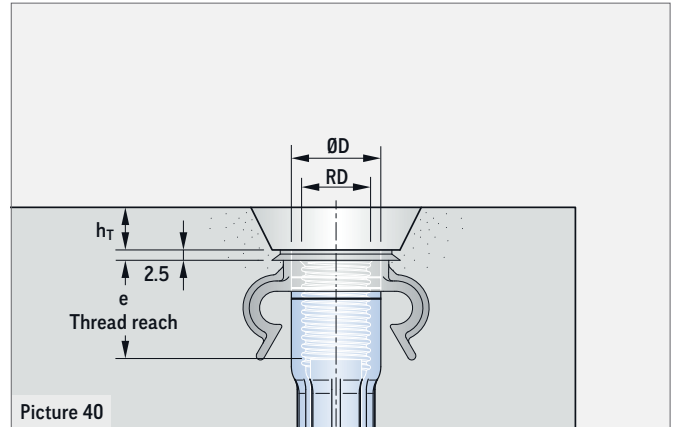
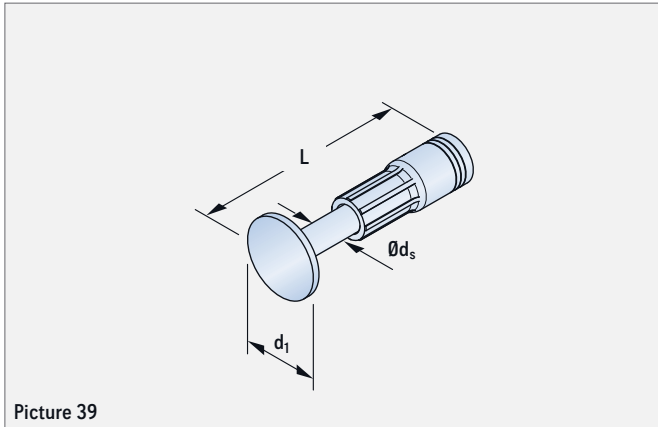

The short version of the Compact anchor SR is used for a planar installation in slab-like elements. It is part of the PHILIPP Transport anchor system and complies with the VDI/BV-BS Guideline "Lifting inserts and lifting systems for precast concrete elements" (VDI/BV-BS 6205).

The use of transport anchors requires the compliance with this Installation and Application Instruction as well as the General Installation and Application Instruction. The anchor may only be used in combination with the mentioned PHILIPP lifting devices of the SR system.

TABLE 11: DIMENSIONS OF THE COMPACT ANCHOR SR

Ref. no.	Type	Load class	Dimensions						
			RD	L (mm)	ØD (mm)	Ød _s (mm)	e (mm)	h _T (mm)	d ₁ (mm)
67K160090SR	SR 16	2.5	16	90	21.0	12.5	27	10	35
67K200125SR	SR 20	4.0	20	125	27.0	16.5	35	10	45

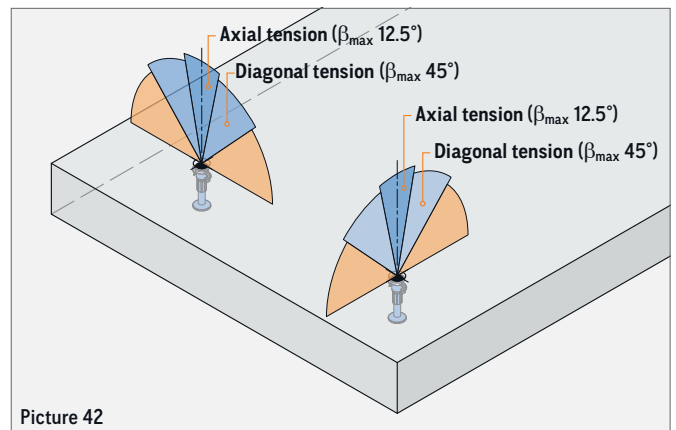
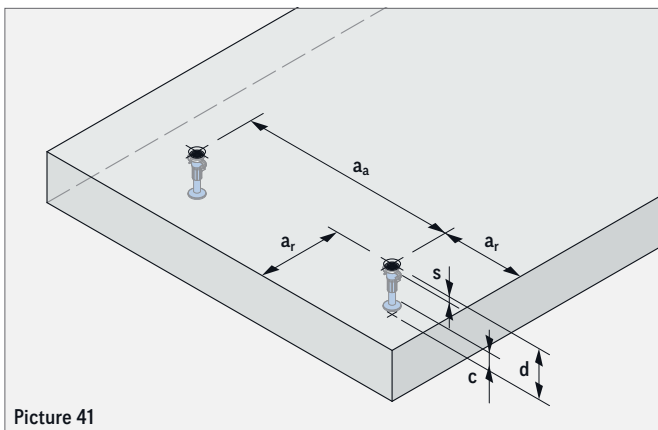

LATERAL TENSION

Lateral tension is not allowed within the whole transport chain. This also applies to a diagonal tension with an angle β more than 45° !

COMPACT ANCHOR SR • WALL-LIKE ELEMENTS • AXIAL TENSION /DIAGONAL TENSION

AXIAL TENSION

If the short version of the Compact anchor SR is loaded with axial tension $\beta_{max} 12.5^\circ$ an additional reinforcement according to table 12 is required.

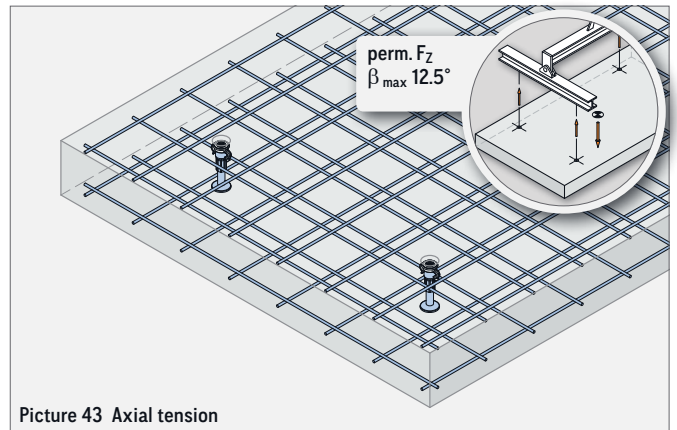

Picture 43 Axial tension

TABLE 12: AXIAL TENSION IF $f_{cc} \geq 15 \text{ N/mm}^2 / 25 \text{ N/mm}^2$

Load class	Min. element thicknesses, min. centre and edge distances			$\beta_{max} 12.5^\circ$			Mesh reinforcement (square) (mm ² /m)
	d (mm)	a _a (mm)	a _r (mm)	$f_{cc} \geq 15 \text{ N/mm}^2$ (kN)	perm. F _Z $f_{cc} \geq 25 \text{ N/mm}^2$ (kN)	$f_{cc} \geq 35 \text{ N/mm}^2$ (kN)	
2.5	125	270	180	21.4	21.4	25.0	2 × #188
4.0	160	375	250	33.1	40.0	25.0	2 × #188

The weight of 1.0 t corresponds to 10.0 kN.

DIAGONAL TENSION

If the Compact anchor SR is loaded with diagonal tension $\beta_{max} 45^\circ$ an additional reinforcement according to table 13 is required.

Here the reinforcement for diagonal tension is placed contrarily to the tensile direction (picture 44) and must have direct pressure contact to the anchor insert in the peak of its bending.

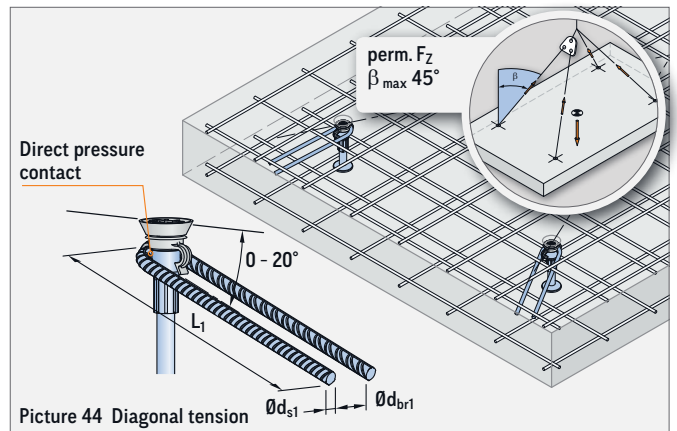

Picture 44 Diagonal tension

TABLE 13: DIAGONAL TENSION $f_{cc} \geq 15 \text{ N/mm}^2$

Load class	Min. element thicknesses, min. centre and edge distances			perm. F _Z $f_{cc} \geq 15 \text{ N/mm}^2$ (kN)	$\beta_{max} 45^\circ$			
	d (mm)	a _a (mm)	a _r (mm)		Mesh reinforcement (square) (mm ² /m)	Rebar for diagonal tension (B500B)		
						Ød _{s1} (mm)	L ₁ (mm)	Ød _{br1} (mm)
2.5	125	270	180	13.4	2 × #188	10	350	40
4.0	160	375	250	26.3	2 × #188	12	470	48

The weight of 1.0 t corresponds to 10.0 kN.

THREADED ELONGATION SR

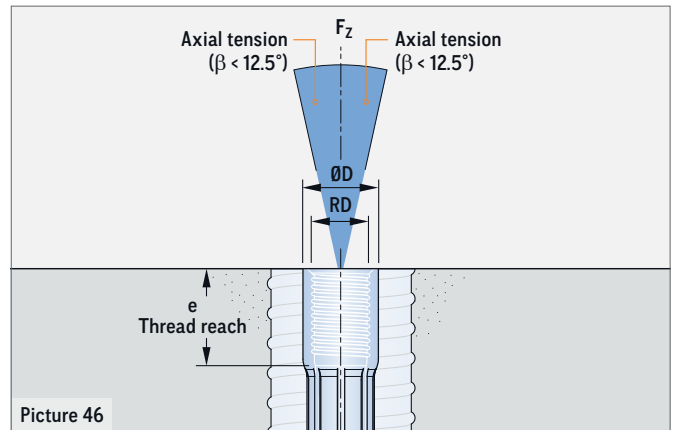
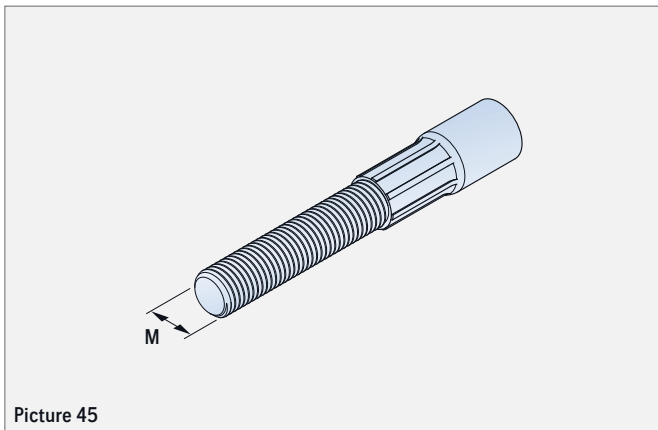

The Threaded transport anchor elongation SR is designed especially for the transport of precast concrete cubicles with additional attached roof slabs. The elongation is screwed through a recess in the roof slab in the transport anchor of the cubicle. The Threaded transport anchor elongation is part of the PHILIPP Transport anchor system and complies with the VDI/BV-BS Guideline "Lifting anchors and lifting systems for precast concrete elements" (VDI/BV-BS 6205). The use of Threaded transport anchors requires the compliance with this Installation and Application Instruction as

well as the General Installation and Application Instruction. The anchors may only be used in combination with the mentioned PHILIPP lifting devices of the SR system.

A Threaded transport anchor elongation SR is designed for the transport of precast concrete units only. Multiple use within the transport chain (from production to installation of the unit) means no repeated usage. The Threaded transport anchor elongation SR is not specified for a repeated usage (e.g. ballasts for cranes) or a permanent fixation.

TABLE 14: DIMENSIONS THREADED TRANSPORT ANCHOR ELONGATION SR

Ref. no. galvanised bright zinc plated ④	Type	Load class	Dimensions			
			RD / M	$L_{v,min}$ (mm)	ØD (mm)	e (mm)
67AVLSR12___	SR 12	1.3	12	40	15.0	22
67AVLSR16___	SR 16	2.5	16	55	21.0	27
67AVLSR20___	SR 20	4.0	20	65	27.0	35
67AVLSR24___	SR 24	5.0	24	75	31.0	43
67AVLSR30___	SR 30	8.0	30	105	39.5	56
67AVLSR36___	SR 36	10.0	36	110	47.0	68
67AVLSR42___	SR 42	14.5	42	135	54.0	75
67AVLSR52___	SR 52	20.0	52	180	67.0	95

④ The elongation length L_v (see page 29) has to be added to the reference number.

MATERIALS

The Threaded anchor elongation SR consists of a threaded rod with a crimped-on insert. These threaded inserts are made of special high precision steel tubes and are galvanized according

to common standards. This galvanization protects the anchor temporarily, from the storage at the producer site to the final installation in the concrete element.

THREADED ELONGATION SR

CALCULATION OF THE ELONGATION LENGTH L_V

The elongation length is determined by the height of the additional roof slab, the possible joint (for grouting) and recess for an anchor installation in recessed position (in the cubicle). The dimension $L_{V,min}$ (table 14) must not be less than this.

Calculation of the elongation length L_V

$$L_V = h_B + h_F + h_T$$

Check of the minimum length

$$L_V \geq L_{V,min} \text{ (see table 14)}$$

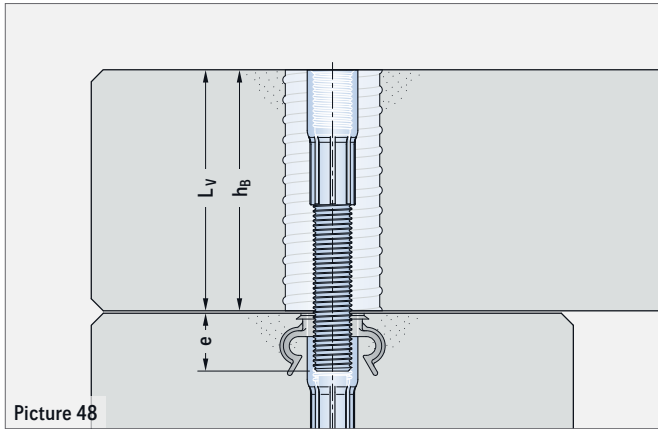

Picture 48

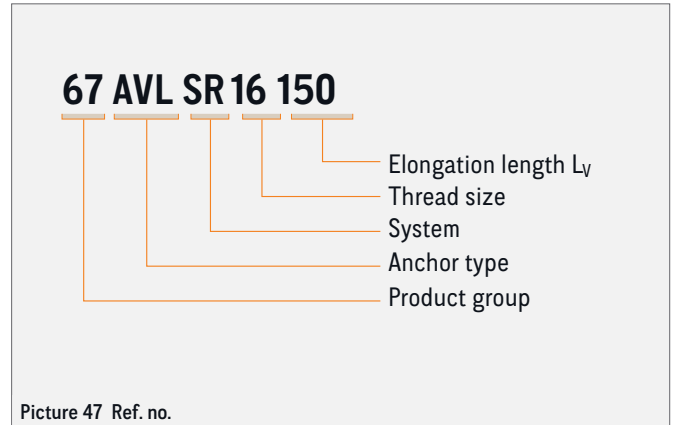

Picture 47 Ref. no.

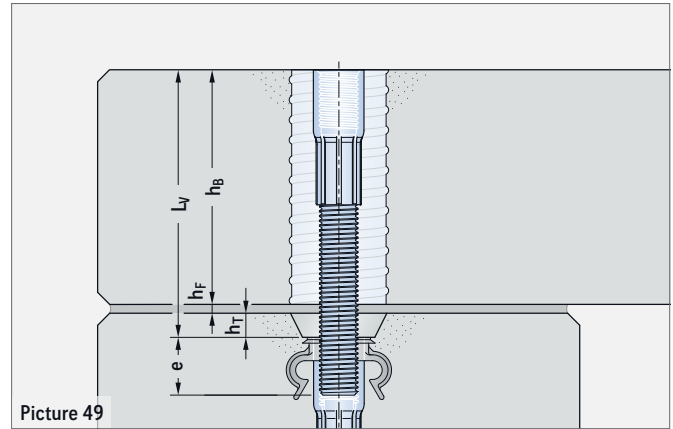

Picture 49

LOAD DIRECTIONS

The Threaded transport anchor elongation SR is only suitable for axial load ($\beta \leq 12.5^\circ$). Diagonal and lateral tension is not permissible within the complete transport chain!

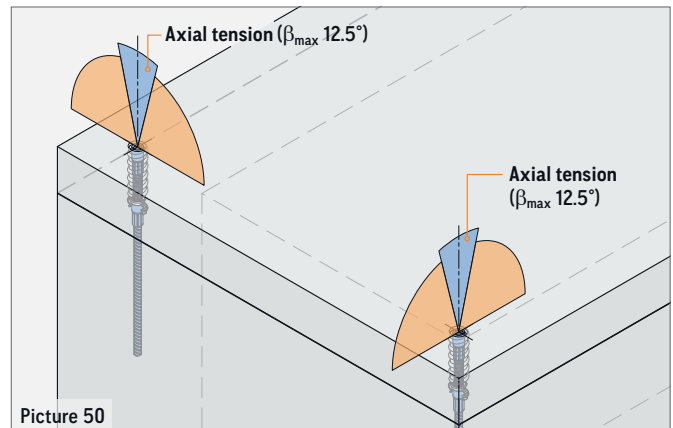

Picture 50

THREADED TRANSPORT ANCHOR ELONGATION SR

INSTALLATION

Before using the Threaded transport anchor elongation SR please check if the minimum thread reach of the elongation ($e_{A,min}$) can be reached (picture 51). If this is correct, the Threaded transport anchor elongation SR can be screwed in flush to the concrete surface. If the minimum thread reach is not reached ($e_{A,min}$), the Threaded transport anchor elongation SR must be screwed in re-

cessed position. Here, the Application Instruction of the used lifting device must be considered. After screwing-in the area around the Threaded transport anchor elongation SR must be completely grouted with mortar. In order to avoid a soiling of the thread we recommend to protect the insert (e.g. by using a PHILIPP 72KAS__).

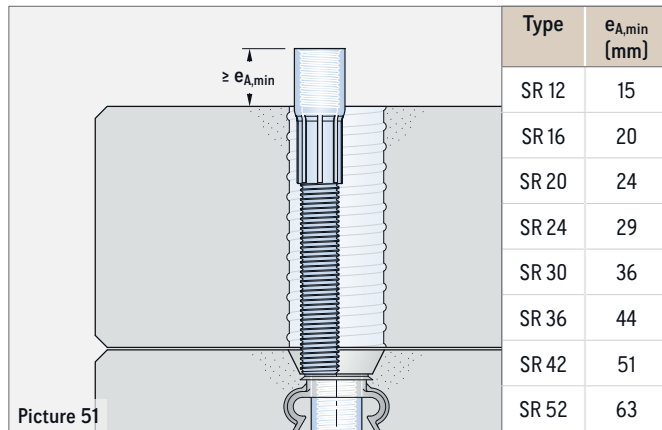

Picture 51

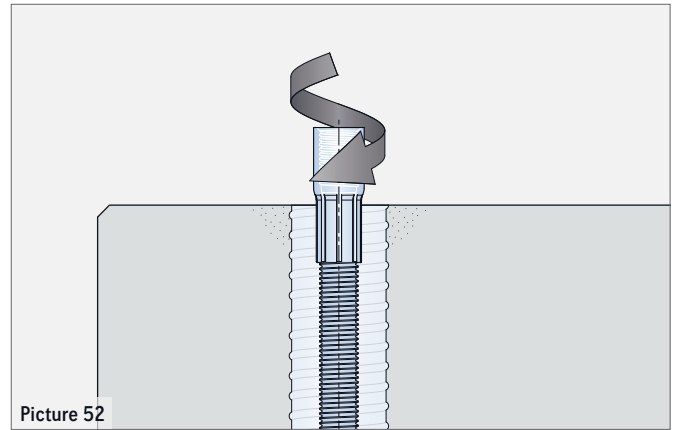

Picture 52

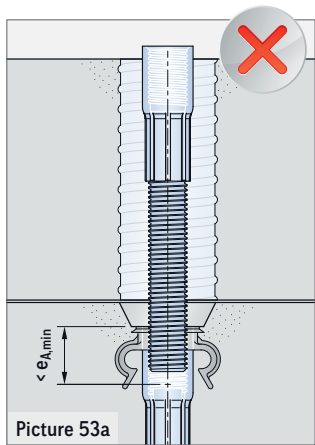

Picture 53a

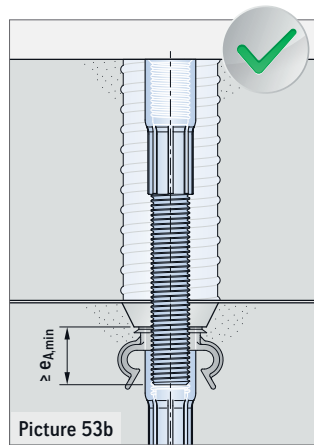

Picture 53b

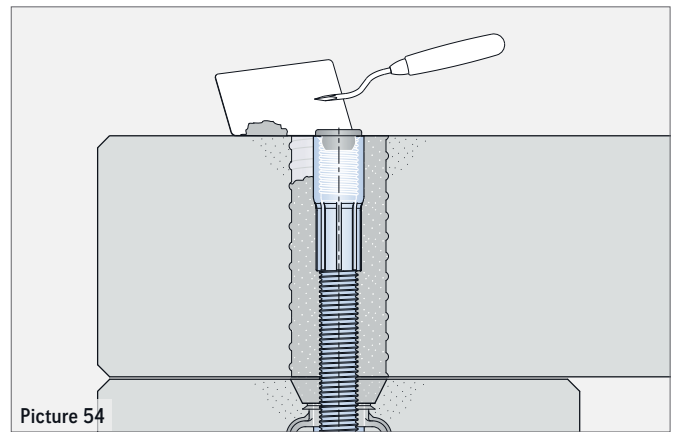

Picture 54

ACCESSORIES FOR THE POWER SYSTEM SR

MARKING RING SR WITH CLIP

The Marking ring SR with clip is used for marking the installed anchor as well as to fix additional reinforcement to the right position of the threaded insert (reinforcement for lateral or diagonal tension, see picture 58).

The plastic Marking ring SR with clip is put over the threaded insert prior the installation of the anchor. Finally, the Threaded transport anchor SR is fixed to the formwork by a recess former (plastic, steel or magnet version).

Due to the colour-coded marking a quick and correct classification of the corresponding lifting device is ensured.

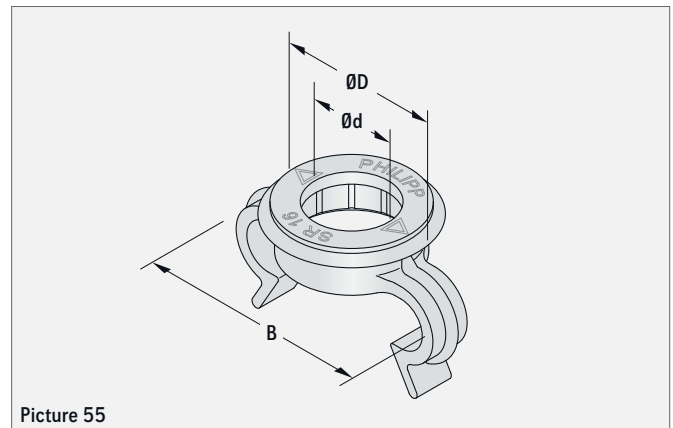

Picture 55

TABLE 15: MARKING RING SR WITH CLIP

Ref. no.	Type	ØD (mm)	Ød (mm)	B (mm)	Colour code
74KR12CLIPSR	SR 12	26	13	38	● Flame red
74KR16CLIPSR	SR 16	31	17	49	● Silk grey
74KR20CLIPSR	SR 20	37	21	69	● Emerald green
74KR24CLIPSR	SR 24	41	25	63	● Light blue
74KR30CLIPSR	SR 30	52	31	80	● Claret violet
74KR36CLIPSR	SR 36	57	36	97	● Pastel orange
74KR42CLIPSR	SR 42	64	43	104	● Clay brown
74KR52CLIPSR	SR 52	80	53	117	● Jet black

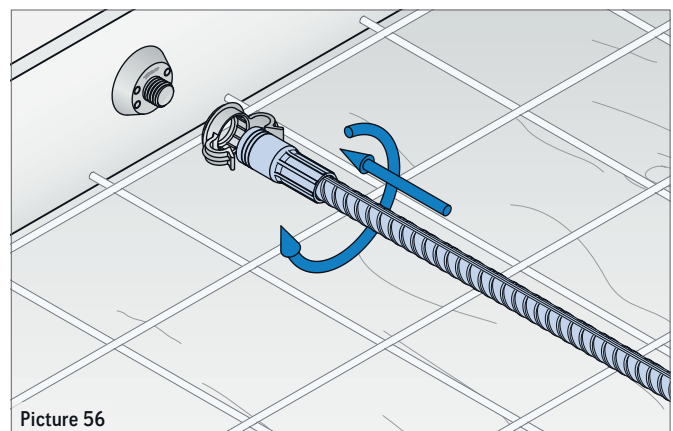

Picture 56

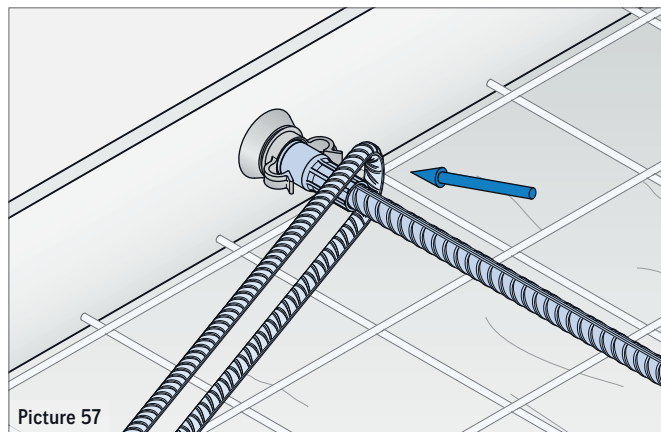

Picture 57

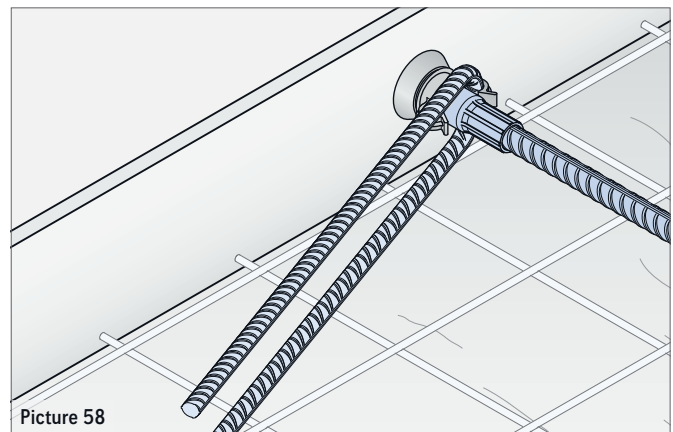

Picture 58

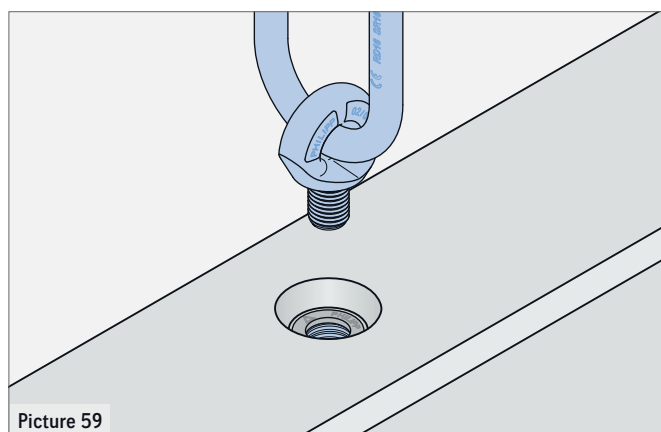

Picture 59

ACCESSORIES FOR THE POWER SYSTEM SR

PLASTIC RECESS FORMER SR

Firstly, the Plastic recess formers SR are fixed to the formwork by nailing or hot bonding. Now the Threaded transport anchor SR can be screwed onto the fixed recess former. In order to avoid a change of position of the transport anchor during concreting, it may be necessary, depending on the length of the transport anchor, to fix it additionally to the reinforcement of the concrete element. After the demoulding, the Plastic recess former SR can be quickly and easily removed e.g. with the PHILIPP tool 72KHNS (page 37).

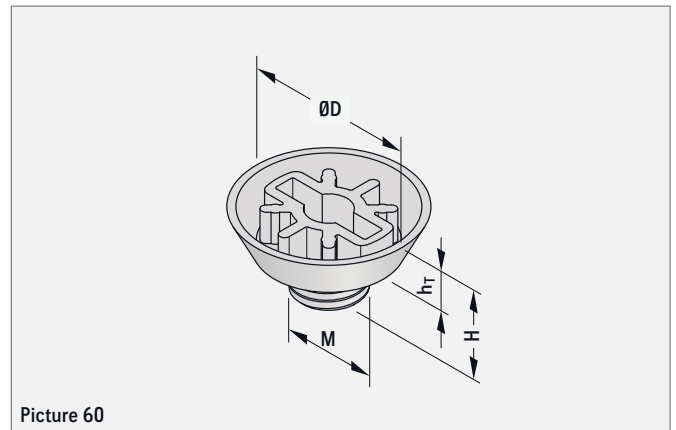

Picture 60

TABLE 16: PLASTIC RECESS FORMER SR

Ref. no.	Type	M Thread	ØD (mm)	H (mm)	h _T (mm)	Colour code
72KHN12SR	SR 12	M12	40	20	10	Flame red
72KHN16SR	SR 16	M16	40	20	10	Silk grey
72KHN20SR	SR 20	M20	55	25	10	Emerald green
72KHN24SR	SR 24	M24	55	25	10	Light blue
72KHN30SR	SR 30	M30	70	30	10	Claret violet
72KHN36SR	SR 36	M36	70	30	10	Pastel orange
72KHN42SR	SR 42	M42	96	35	12	Clay brown
72KHN52SR	SR 52	M52	96	35	12	Jet black

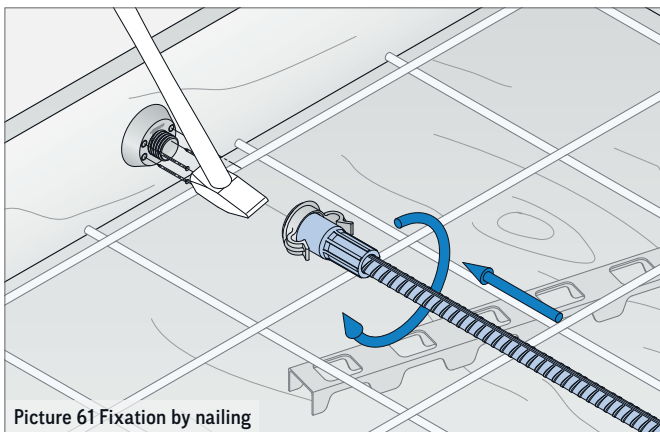

Picture 61 Fixation by nailing

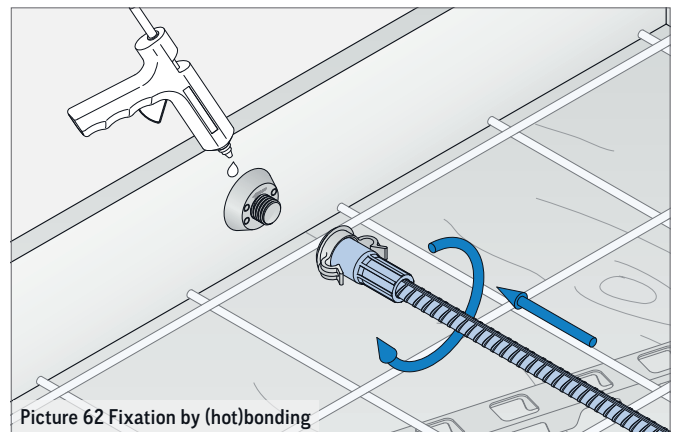

Picture 62 Fixation by (hot)bonding

ACCESSORIES FOR THE POWER SYSTEM SR

STEEL RECESS FORMER KHN

With Steel recess formers Threaded transport anchors can be fixed with screws (with metric thread) or nails to the formwork. Depending on the length of the Threaded transport anchors, it may be necessary to fix the anchor to the reinforcement of the concrete element additionally.

After demoulding, the Steel recess former can be quickly and easily removed with an Allen key (see table 17).

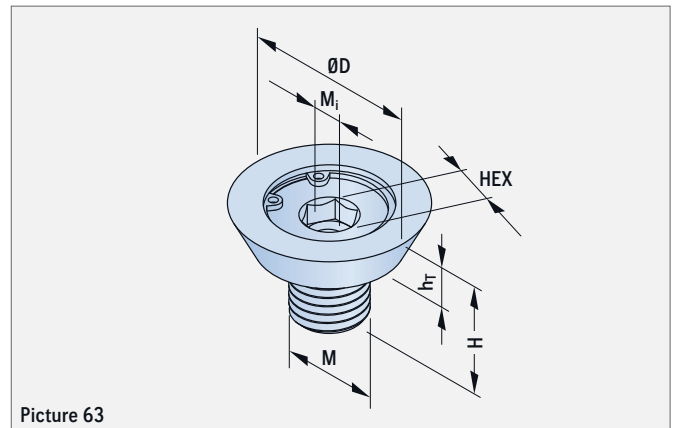

Picture 63

TABLE 17: STEEL RECESS FORMER KHN

Ref. no.	Type / M	ØD (mm)	H (mm)	h _T (mm)	M _i	HEX (mm)
72KHN12STK	M 12	40	23	10	M 6	8
72KHN16STK	M 16	40	27	10	M 8	10
72KHN20STK	M 20	55	31	10	M 8	10
72KHN24STK	M 24	55	35	10	M 10	14
72KHN30STK	M 30	70	43	10	M 10	14
72KHN36STK	M 36	70	48	10	M 10	14
72KHN42STK	M 42	96	59	12	M 16	17
72KHN52STK	M 52	96	69	12	M 16	17

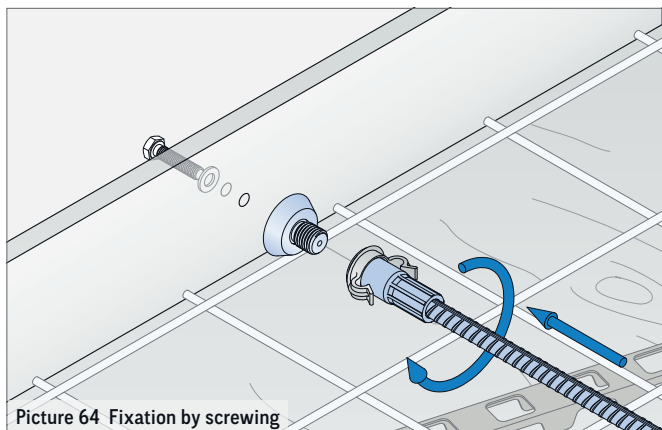

Picture 64 Fixation by screwing

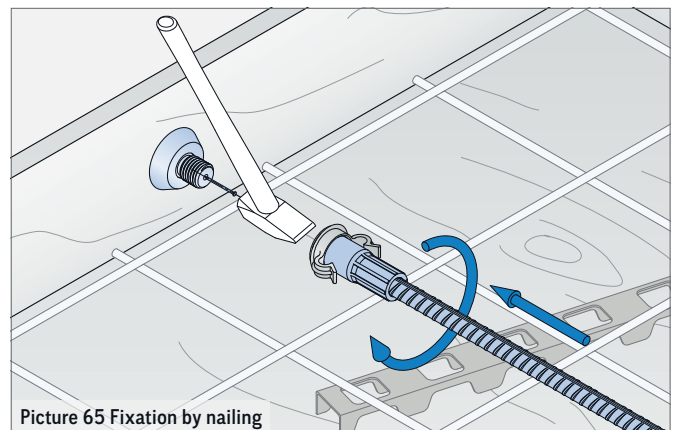

Picture 65 Fixation by nailing



NOTE

If nails are used to fasten the Steel recess former, ensure that they are not too large resp. too long, as they may interfere with the unscrewing of the recess formers. In this case, Allen keys with a hole can be used. Alternatively, the nails sticking out can be pressed into the insert of the threaded transport anchor (if they are too long - they need to be shortened!) so that a removal with standard Allen keys is possible.

ACCESSORIES FOR THE POWER SYSTEM SR

MAGNETIC RECESS FORMER KHN

The Magnetic recess formers are fixed to the steel formwork with a screwed-on transport anchor. Here, a correction of the position on the formwork is possible at any time. In order to avoid a change of the position of the transport anchor during concreting, it may be necessary, depending on the length of the anchor, to fix it additionally to the reinforcement of the concrete element.

After the demoulding, the Magnetic recess former can be quickly and easily removed with an Allen key (see table 18). In order to achieve the optimum adhesive of the Magnet recess former the adhesive surface of the recess former and the steel formwork shall be cleaned after use.

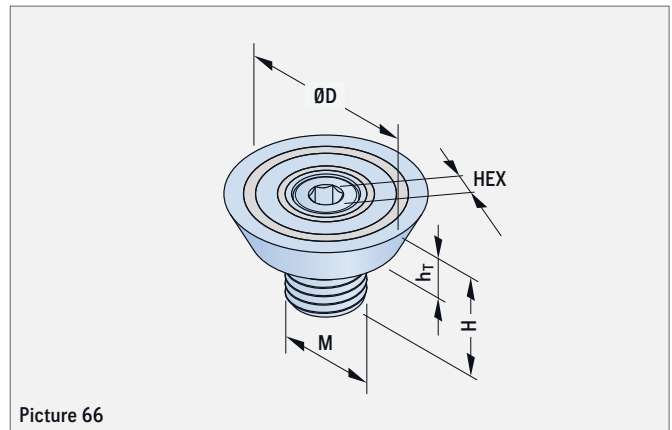

Picture 66

TABLE 18: MAGNETIC RECESS FORMER KHN

Ref. no.	Type / M	ØD (mm)	H (mm)	h _T (mm)	HEX (mm)	Adhesion (kg)
72MAXKHN12	M 12	40	25	10	6	60
72MAXKHN16	M 16	40	25	10	6	60
72MAXKHN20	M 20	55	30	10	8	100
72MAXKHN24	M 24	55	30	10	8	100
72MAXKHN30	M 30	70	30	10	8	180
72MAXKHN36	M 36	70	30	10	8	180
72MAXKHN42	M 42	96	35	12	8	180
72MAXKHN52	M 52	96	35	12	8	180



FURTHER INFORMATION

HANDLING!

Improper handling may result in skin bruises and haematomas. Due to the high impact speeds, parts of the magnet can splinter and cause injuries. Magnets do not belong in children's hands. Also swallowing of the magnets can cause serious medical problems. Persons with pacemakers are advised to keep a certain safety distance to strong magnets. Also direct contact with magnetic materials can lead to allergic reactions (e.g. Against ceramic and metallic materials as well as zinc, nickel or plastics).

TEMPERATURE!

Please note that the magnets have a maximum operating temperature of 80 °C. At temperatures above 80 °C, they may permanently lose some of their adhesive force.

EFFECT!

Please notice that magnetic fields can delete data media such as hard disks, cards with magnetic stripes etc. Electronic and mechanic components such as pacemaker, watches, counters, compasses, displays can be influenced or destroyed. Therefore, keep a distance of at least one metre to these objects.



NOTE ON CONCRETING

If concrete is poured over the magnetically fixed transport anchor, the magnetic recess former on the formwork may be displaced. To avoid this, the area of the anchor must be skipped during concreting.

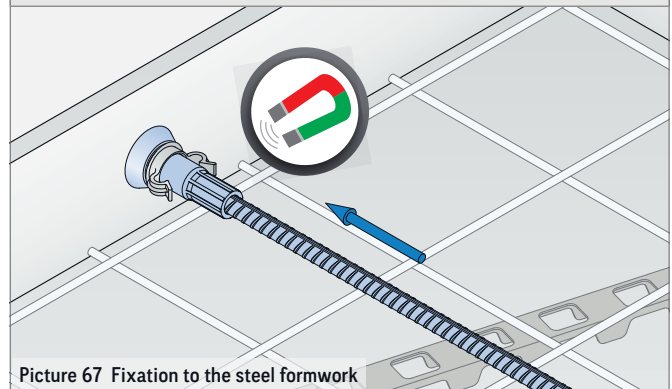

Picture 67 Fixation to the steel formwork

RESPONSIBILITY!

The magnets are coated to protect them. This coat can be removed during normal use. Splintering of the coating is possible when magnets collide. But this does not affect the performance of the magnets and is no reason for complaint. Mechanical influences such as welding or grinding must be avoided in all cases.

ACCESSORIES FOR THE POWER SYSTEM SR

PLASTIC RECESS FORMER SR SZ15

By using the Plastic recess former SR SZ15 Threaded transport anchors can be fixed with an angle of 15° to the formwork. Then, the Threaded transport anchor is screwed onto the recess former attached to the formwork. Depending on the length of the Threaded transport anchor, it may be necessary to fix it additionally to

the reinforcement of the concrete element. After the demoulding, the Plastic recess former SR SZ15 can be quickly and easily removed e.g. with the PHILIPP tool 72KHNS (page 37).

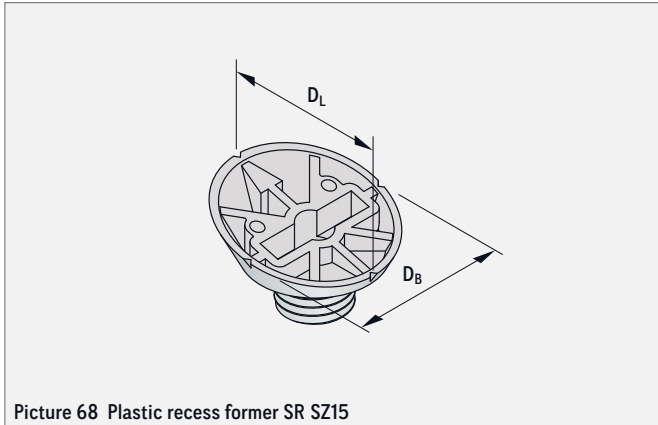



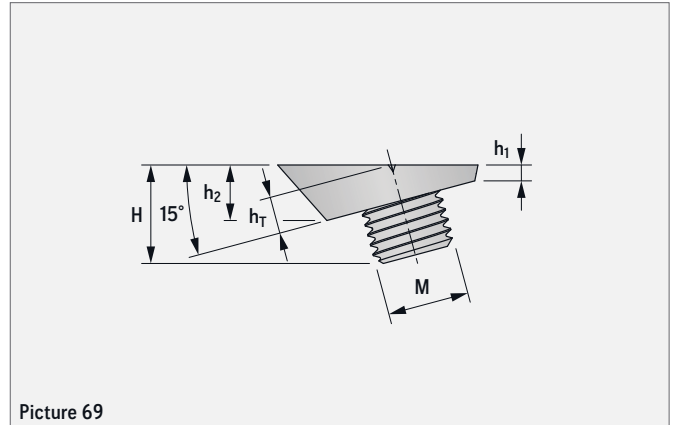



Picture 68 Plastic recess former SR SZ15



Picture 69

TABLE 19: PLASTIC RECESS FORMER SR SZ15

Ref. no.	Type	Dimensions							Colour code
		M Thread	D_L (mm)	D_B (mm)	H (mm)	h_1 (mm)	h_2 (mm)	h_T (mm)	
72KHN16SR-SZ15	SR 16	M16	38.5	38.0	20.5	3.5	11.2	7.5	 Silk grey
72KHN20SR-SZ15	SR 20	M20	55.5	55.0	30.5	3.3	15.0	9.5	 Emerald green
72KHN24SR-SZ15	SR 24	M24	55.5	55.0	31.0	3.3	15.0	9.5	 Light blue
72KHN30SR-SZ15	SR 30	M30	72.5	72.0	38.5	3.2	18.7	11.5	 Claret violet
72KHN36SR-SZ15	SR 36	M36	72.5	72.0	39.0	3.2	18.7	11.5	 Pastel orange
72KHN42SR-SZ15	SR 42	M42	99.5	99.0	48.0	3.3	25.5	15.0	 Clay brown
72KHN52SR-SZ15	SR 52	M52	99.5	99.0	49.5	3.3	25.5	15.0	 Jet black

MARKING

Due to its colour code as well as the marking with the load class (thread size), an easy matching of the recess formers to the Threaded transport anchors to be fixed and the required lifting devices is ensured.

For a fast mounting of the recess former to the formwork small notches on the edge are given to mark the anchor axis. In addition, a marking indicates the installation direction (later load direction of the transport anchors).

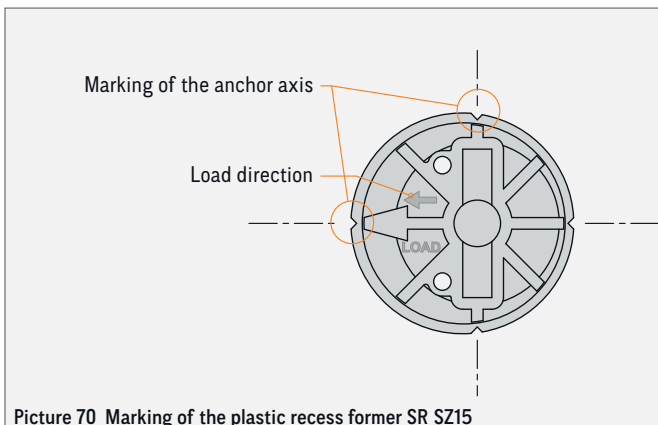

Picture 70 Marking of the plastic recess former SR SZ15

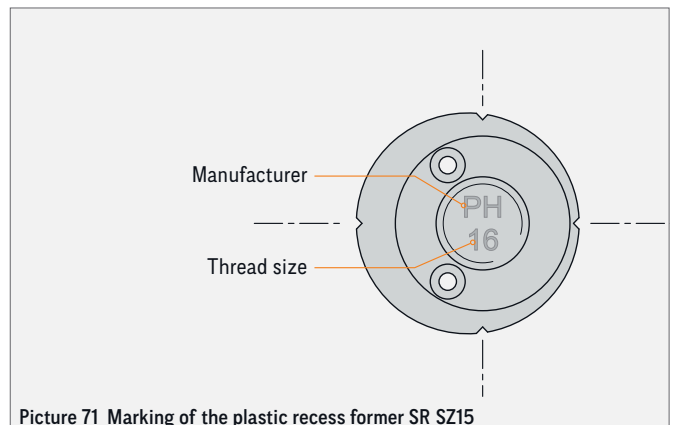

Picture 71 Marking of the plastic recess former SR SZ15

ACCESSORIES FOR THE POWER SYSTEM SR

STEEL RECESS FORMER KHN SZ15

By using the Steel recess former SZ15 Threaded transport anchors can be fixed with nails in an angle of 15° to the formwork. Then, the Threaded transport anchor is screwed onto the recess former attached to the formwork.

After the demoulding, the Steel recess former SZ15 can be quickly and easily removed with an Allen key (see table 20).

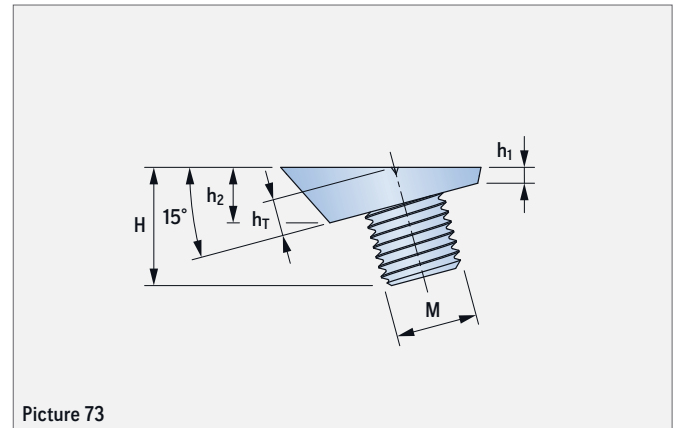
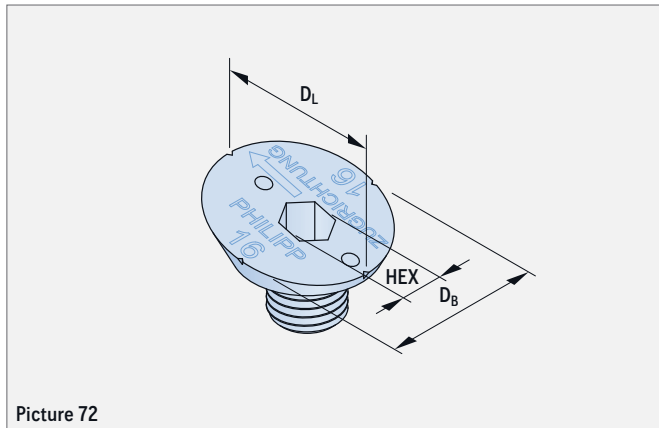

TABLE 20: STEEL RECESS FORMER KHN SZ15

Ref. no.	Type / M	DL (mm)	DB (mm)	H (mm)	h1 (mm)	h2 (mm)	hT (mm)	HEX (mm)
72KHN16-SZ15	M16	38.5	38.0	23.5	3.5	11.2	7.5	8
72KHN20-SZ15	M20	55.5	55.0	30.5	3.3	15.0	9.5	10
72KHN24-SZ15	M24	55.5	55.0	31.0	3.3	15.0	9.5	10
72KHN30-SZ15	M30	72.5	72.0	38.0	3.2	18.7	11.5	10
72KHN36-SZ15	M36	72.5	72.0	39.0	3.2	18.7	11.5	10
72KHN42-SZ15	M42	99.5	99.0	48.0	3.3	25.5	15.0	10
72KHN52-SZ15	M52	99.5	99.0	50.0	3.3	25.5	15.0	10

MARKING

With the marking of the load class (thread size), an easy matching of the recess formers to the Threaded transport anchors SR to be fixed is ensured. For a fast mounting of the recess former to the formwork small notches on the edge are given to mark the anchor axis.

In addition, a marking indicates the installation direction (later load direction of the transport anchors).

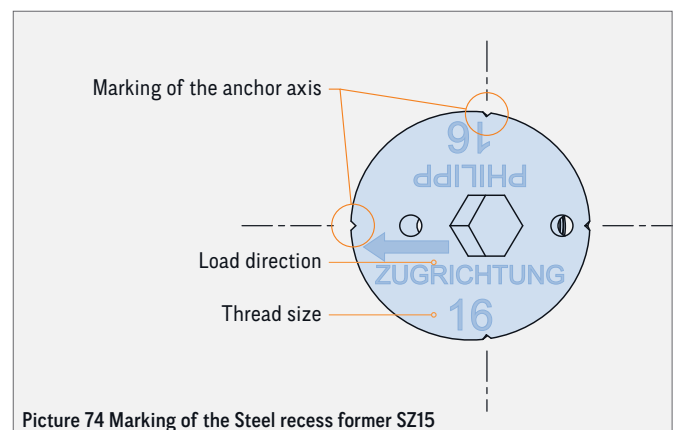

ACCESSORIES FOR THE POWER SYSTEM SR

TOOL/KEY FOR PLASTIC RECESS FORMER SR

The tool/key is used for an easy unscrewing of the Plastic recess former of the Threaded transport anchors SR set in concrete. Because of its special geometry, the tool/key can be used for all sizes (standard and SZ15, type SR 12-52) of the SR system.

TABLE 21: KEY - PLASTIC RECESS FORMER SR

Ref. no.	Type M/SR/SL	L (mm)	b (mm)
72KHNS	12 - 52	200	57

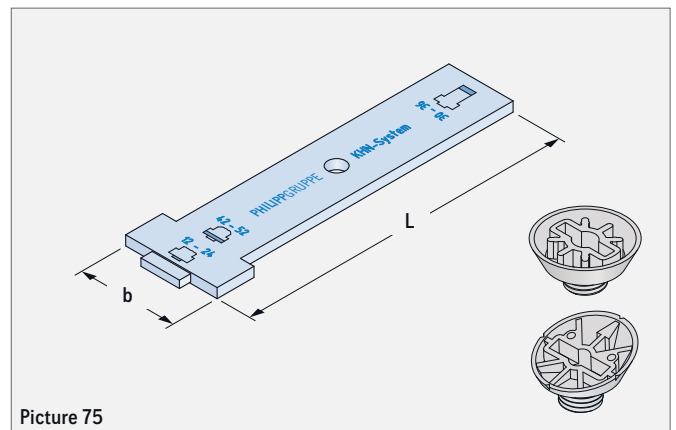

Picture 75

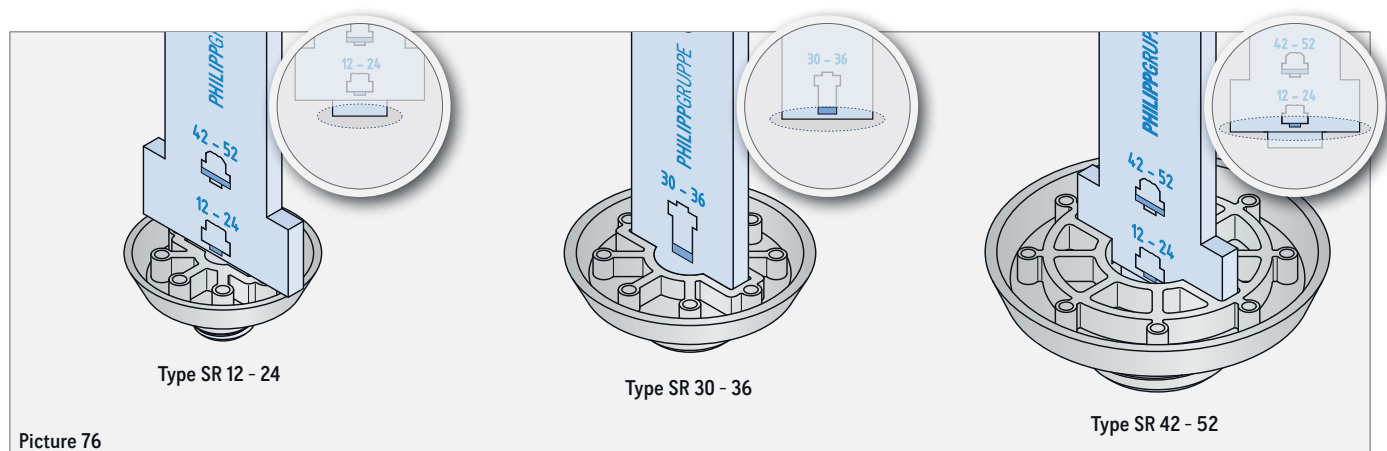

Picture 76

ACCESSORIES FOR THE POWER SYSTEM SR

SEALING CAP KHN (PLASTIC)

The Sealing cap KHN (plastic) covers the complete range of thread sizes from 12 to 52 (table 22) with only four types. As the Plastic sealing cap is only pressed into the Threaded transport anchor, it has no disturbing recesses on the visible surface for screwing in and out (slot, hexagon socket). Hence, the Sealing cap in plastic offers a visual attractive solution to close recesses surface-flush.

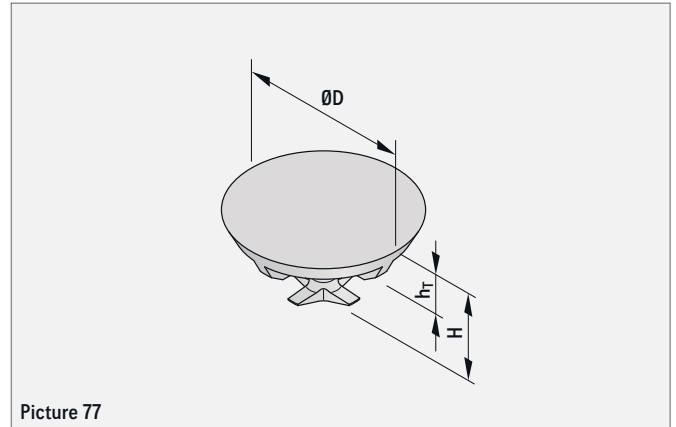

Picture 77



NOTE

Sealing caps are used exclusively as visual attractive closing of the recesses. In order to avoid damage to the concrete element (e.g. spalling due to frost), the user shall ensure that the Sealing caps are protected against moisture penetration.

TABLE 22: SEALING CAP KHN (PLASTIC)

Ref. no.	Type	ØD (mm)	h _T (mm)	H (mm)
72ASKHN040FB	M/RD/SR/SL 12 - 16	40	10	20
72ASKHN055FB	20 - 24	55	10	28
72ASKHN070FB	30 - 36	70	10	40
72ASKHN096FB	42 - 52	96	12	60

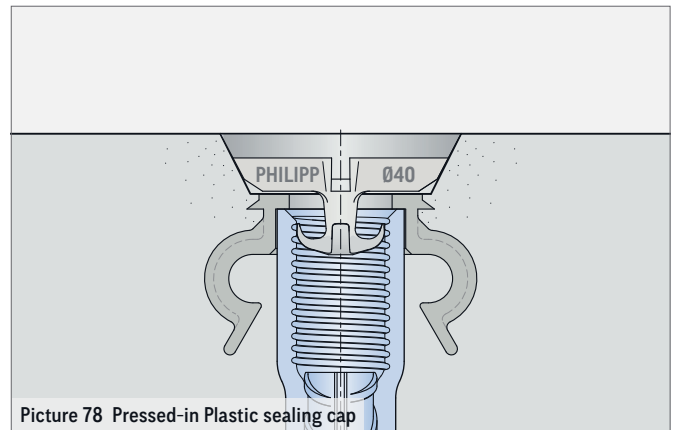

Picture 78 Pressed-in Plastic sealing cap

REMOVING THE PLASTIC SEALING CAP

In order to remove the Plastic sealing cap, punch a big screwdriver centrally into it.

Then it can be removed resp. unscrewed.

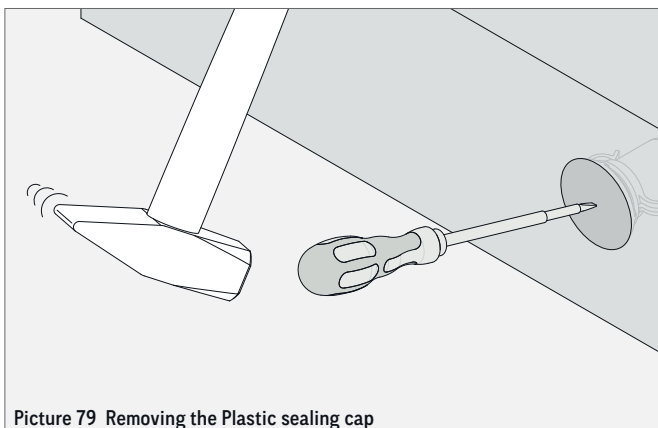

Picture 79 Removing the Plastic sealing cap

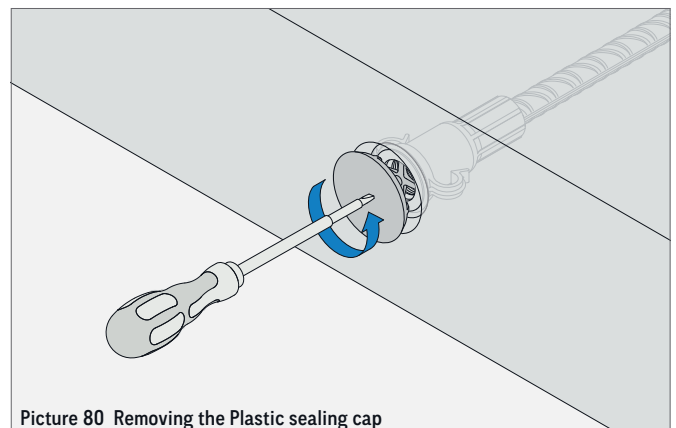

Picture 80 Removing the Plastic sealing cap

ACCESSORIES FOR THE POWER SYSTEM SR

SEALING CAP KHN (CONCRETE)

The Sealing cap KHN made of concrete covers the complete range of thread sizes from 12 to 52 (table 23) with only four types. Furthermore it offers an visual attractive solution to close recesses surface-flush.

NOTE

Sealing caps are used exclusively as visual attractive closing of the recesses. In order to avoid damage to the concrete element (e.g. spalling due to frost), the user shall ensure that the Sealing caps are protected against moisture penetration.

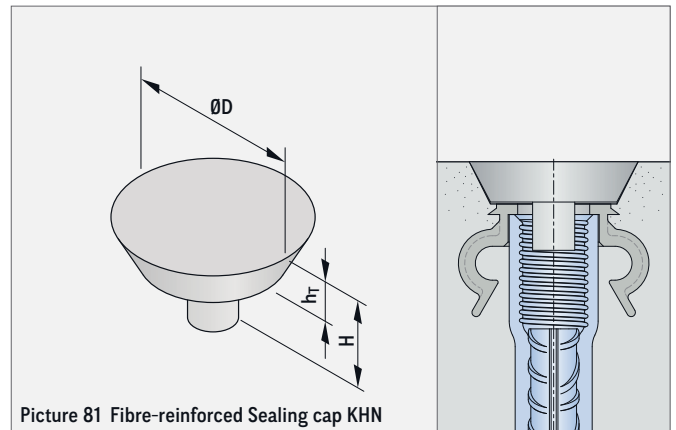

Picture 81 Fibre-reinforced Sealing cap KHN

TABLE 23: SEALING CAP KHN (CONCRETE)

Ref. no.	Type	ØD (mm)	h _T (mm)	H (mm)
	M/RD/SR/SL			
72ASKHN040FB	● 12 - 16	40	10	15
72ASKHN055FB	● 20 - 24	55	10	22
72ASKHN070FB	● 30 - 36	70	10	22
72ASKHN096FB	● 42 - 52	96	12	30

Other colours are available on request.

COLOUR VARIATION

This product may vary in colour (within the delivery and to the finished part).

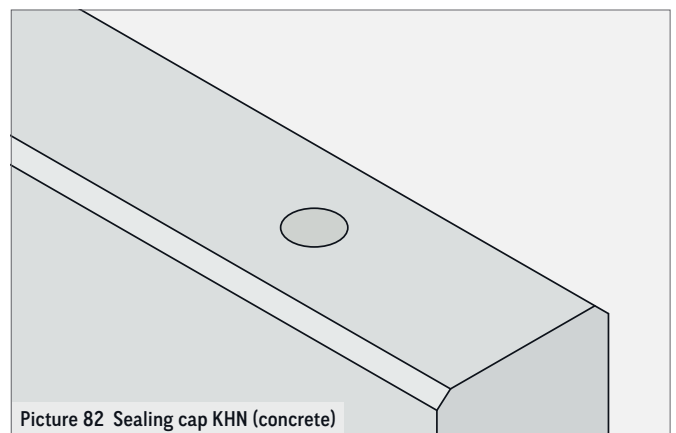

Picture 82 Sealing cap KHN (concrete)

POWER ADHESIVE

The power adhesive is used to glue in the concrete Sealing cap KHN. A complete bonding of the caps significantly reduces the risk of damage e.g. caused by frost.

TABLE 24: POWER ADHESIVE

Ref. no.	Colour	Contents (ml)
72FB-KRAFTKLEBER	● grey	310

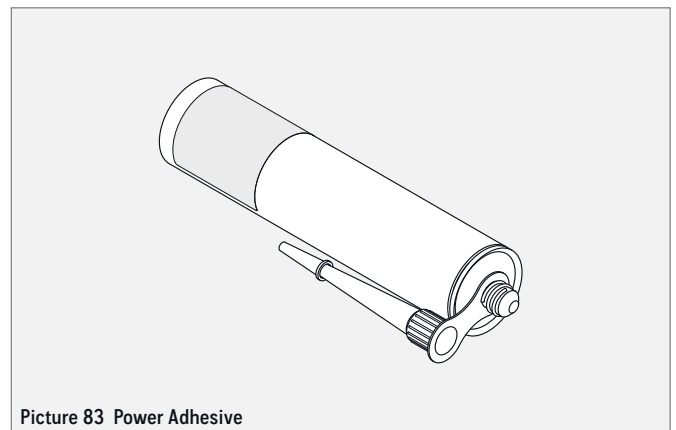

Picture 83 Power Adhesive

NOTE

As a direct force to the Sealing cap (e.g. in stairs) can lead to damage, we recommend to use a stainless steel version instead (see page 40)!

ACCESSORIES FOR THE POWER SYSTEM SR

SEALING CAP KHN (STAINLESS STEEL)

The Sealing cap KHN made of stainless steel is a visually attractive and high-quality solution to close the recesses entirely. It is available with a slot or hexagon socket in the visible surface when installed. The recess created by the former is closed completely by the Sealing cap KHN.



NOTE

Sealing caps are used exclusively as visual attractive closing of the recesses. In order to avoid damage to the concrete element (e.g. spalling due to frost), the user shall ensure that the Sealing caps are protected against moisture penetration.

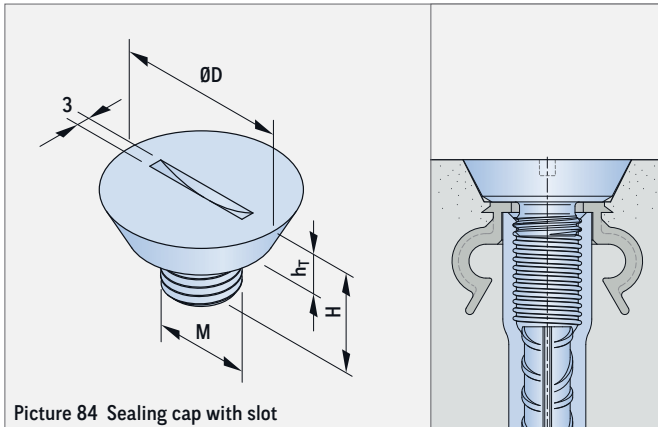

Picture 84 Sealing cap with slot

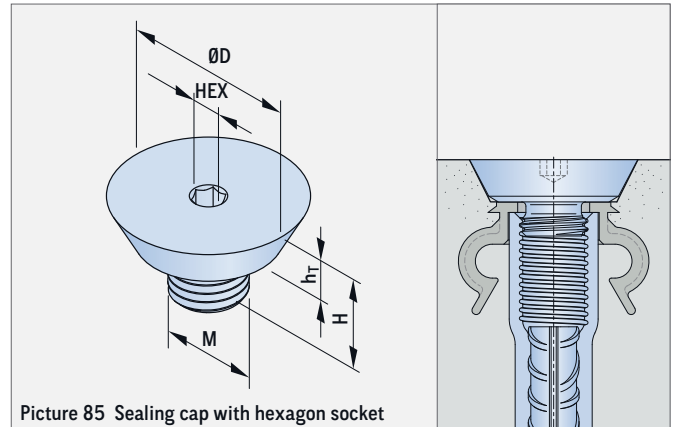

Picture 85 Sealing cap with hexagon socket

TABLE 25: SEALING CAP KHN (STAINLESS STEEL)

Ref. no.		Type / M	ØD (mm)	H (mm)	h _T (mm)	HEX (mm)
with slot	with hexagon socket					
72ASKHN12VA-S	72ASKHN12VA-ISK	M 12	40	18	10	6
72ASKHN16VA-S	72ASKHN16VA-ISK	M 16	40	18	10	6
72ASKHN20VA-S	72ASKHN20VA-ISK	M 20	55	22	10	6
72ASKHN24VA-S	72ASKHN24VA-ISK	M 24	55	22	10	6
72ASKHN30VA-S	72ASKHN30VA-ISK	M 30	70	25	10	6
72ASKHN36VA-S	72ASKHN36VA-ISK	M 36	70	25	10	6
72ASKHN42VA-S	72ASKHN42VA-ISK	M 42	96	30	12	6
72ASKHN52VA-S	72ASKHN52VA-ISK	M 52	96	35	12	6

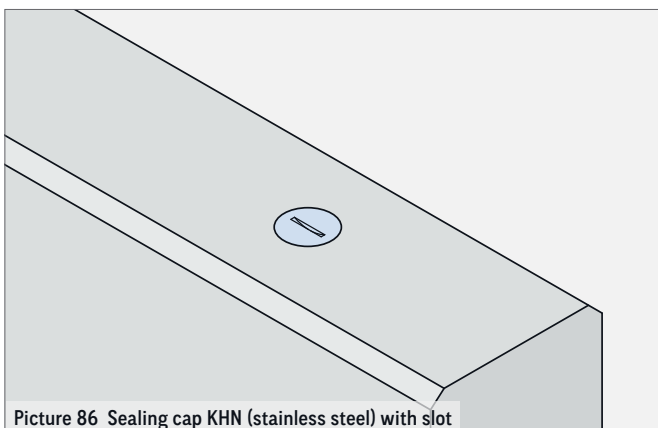

Picture 86 Sealing cap KHN (stainless steel) with slot

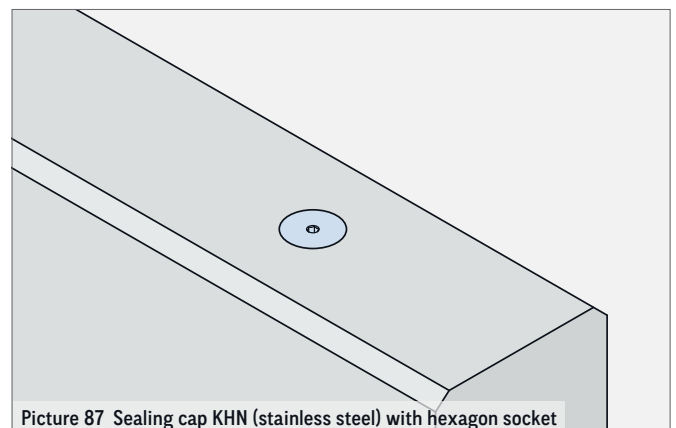

Picture 87 Sealing cap KHN (stainless steel) with hexagon socket

LIFTY SR

The Lifty SR is part of the PHILIPP Transport anchor system and complies with the VDI/BV-BS-Guideline "Lifting inserts and lifting systems for precast concrete elements" (VDI/BV-BS 6205). The use of the Lifty SR requires the compliance with this Installation and Application Instruction as well as the General Installation and Application Instruction. The Lifty SR is suitable for axial, diagonal and lateral tension.

TABLE 26: PERMISSIBLE LOAD BEARING CAPACITIES AND DIMENSIONS

Ref. no.	Type	perm. F 0°- 90° (kN)	Dimensions						Weight (kg/pc.)
			RD	h (mm)	b (mm)	e (mm)	h ₁ (mm)	Ød (mm)	
62LISR12	SR 12	13.0	12	150	50	18	38	13	0.50
62LISR16	SR 16	25.0	16	150	50	23	38	13	0.52
62LISR20	SR 20	40.0	20	162	50	29	53	16	1.00
62LISR24	SR 24	50.0	24	162	50	34	53	16	1.05
62LISR30	SR 30	80.0	30	177	50	43	72	22	2.32
62LISR36	SR 36	100.0	36	202	50	51	72	22	2.63
62LISR42	SR 42	145.0	42	241	65	60	92	28	5.22
62LISR52	SR 52	200.0	52	272	85	73	92	35	7.75

The weight of 1.0 t corresponds to 10.0 kN.

MATERIALS

The Lifty SR consists of a forged ring bolt with a thread and a welded chain link.

APPLICATION

The Lifty SR is a lifting device of the Power Transport anchor system SR and is supplied with a round thread (with metric pitch) or metric thread. It must be screwed into the Threaded transport anchor tightly until the bottom part of the ring bolt has continuous pressure contact in the recess created before in the concrete unit. Therefore an optimal load transfer into the cast-in anchor is given, as the ring bolt is supported by the concrete in case of loading (picture 89).

During rigging the welded chain link must point to the tensile direction at all time. In order to align the Lifty SR into the correct position it is allowed to screw it back for a half turn at the most.

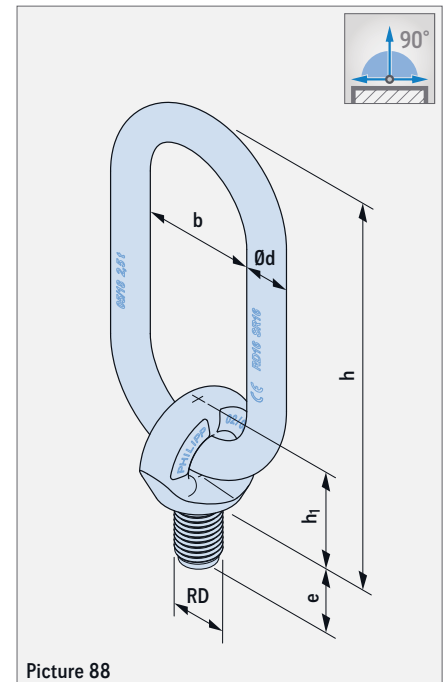

Picture 88

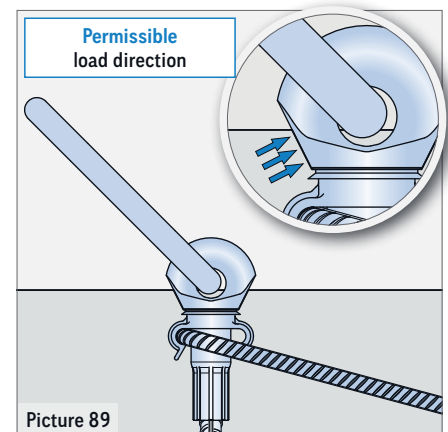

Picture 89



NOTE

Loading the Lifty SR is only admissible in the tensile direction of the ring bolt axis according to picture 90.

LIFTY SR

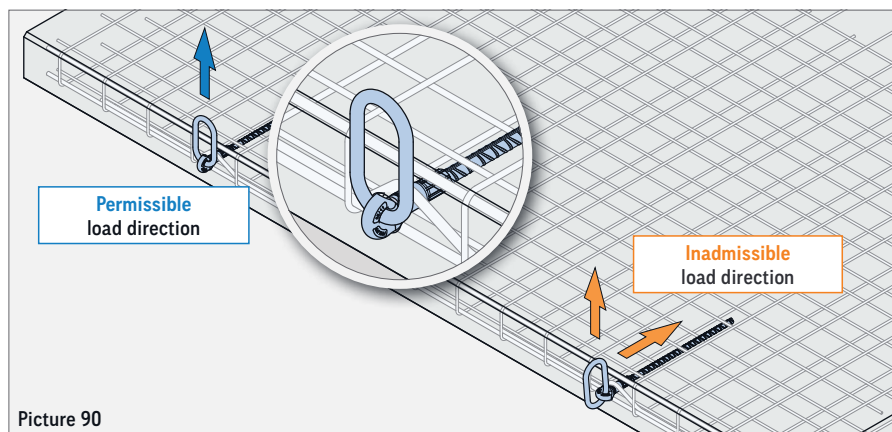

Picture 90

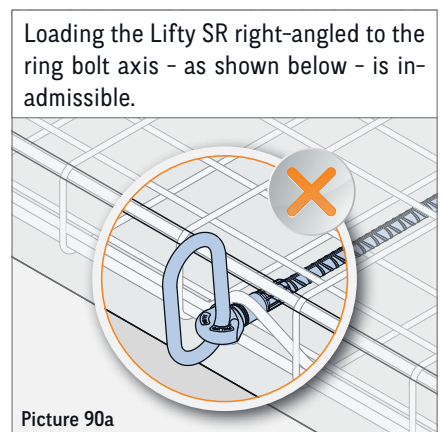

Picture 90a

USE OF ONLY ONE LIFTING DEVICE

Using **only one** Lifty SR in order to lift concrete elements attention must be paid that the Lifty SR is protected against unscrewing (e.g. by using a guy or guide rope at the concrete element).

SAFETY NOTICES

As each other lifting equipment and lifting device the Lifty SR is subject to an annual inspection (acc. to German DGUV regulation 109-017, para. 8.2). This inspection lies within the responsibility of the owner and has to be done by an expert. Depending on the working conditions inspections might be necessary in a shorter interval than once a year. This might be caused by frequent use, increased wear, corrosion or heat treatment.

In general, the current accident prevention regulations must be observed. The correct hook size and form should be considered in order to extend the durability. If the Lifty SR is loaded with extreme loads (e.g. by an event causing damage) which may have influenced the bearing capacity it must be examined extraordinarily by an expert. The criteria are given in section "Safety notices / inspection", page 45-46.

AVOID DAMAGES

In order to avoid damaging the Lifty SR caused by lever action the chain link should not be loaded via a sharp concrete edge (picture 90).

WELDING

Welding or other strong heat influences on the Lifty SR are inadmissible.

CONTINUED USE

The continued use of damaged lifting devices or equipment already met the discard criteria is not permitted!

LIFTY SR DS

The Lifty SR DS is part of the PHILIPP Transport anchor system and complies with the VDI/BV- BS Guideline "Lifting inserts and lifting systems for precast concrete elements" (VDI/BV-BS 6205).

The use of the Lifty SR DS requires the compliance with this Installation and Application Instruction as well as the General Installation and Application Instruction.

TABLE 27: PERMISSIBLE LOAD BEARING CAPACITIES AND DIMENSIONS

Ref. no.	Type	perm. F 0°- 90° (kN)	Dimensions			Weight (kg/pc.)
			RD	h (mm)	e (mm)	
62LISR12DS	SR 12	13.0	12	300	18	0.38
62LISR16DS	SR 16	25.0	16	390	23	1.12
62LISR20DS	SR 20	40.0	20	510	29	2.22
62LISR24DS	SR 24	50.0	24	550	35	2.72
62LISR30DS	SR 30	75.0	30	700	39	5.60
62LISR36DS	SR 36	100.0	36	760	47	7.22
62LISR42DS	SR 42	125.0	42	860	51	10.50

The weight of 1.0 t corresponds to 10.0 kN.

MATERIALS

The Lifty SR DS consists of a forged ring bolt with a thread and a galvanised pressed-steel wire rope.

APPLICATION

The Lifty SR DS is a lifting device of the Threaded transport anchor system and is supplied with a round thread (with metric pitch) or a metric thread. It must be screwed into the Threaded transport anchor tightly until the bottom part of the ring bolt has continuous pressure contact to the recess created before in the concrete unit. Therefore an optimal load transfer into the cast-in anchor is given, as the ring bolt is supported by the concrete in case of loading (picture 92). During rigging the loop of the Lifty SR DS must point to the tensile direction all the time. In order to align the Lifty SR DS into the correct position (picture 93) it is allowed to screw it back for a half turn at the most.

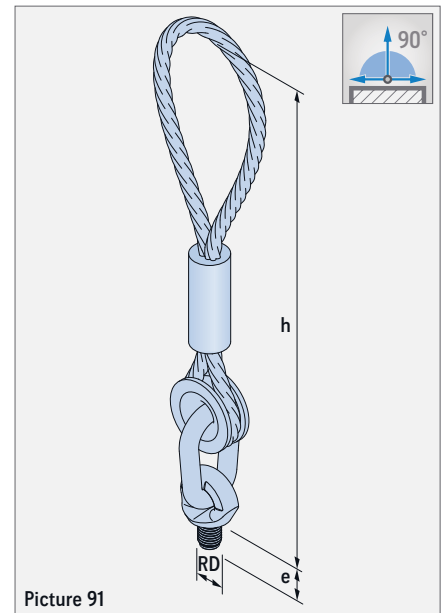

Picture 91

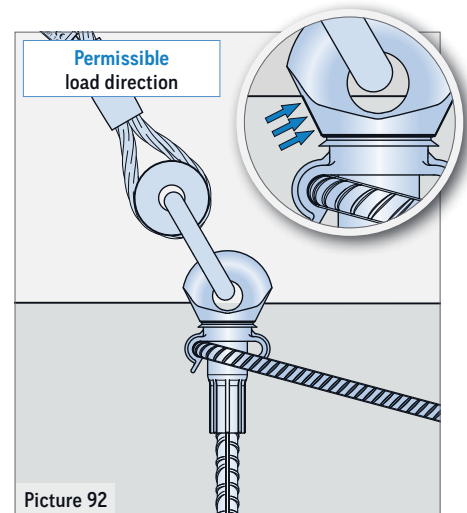

Picture 92



NOTE

Loading the Lifty SR DS is only admissible in the tensile direction of the ring bolt axis according to picture 92.

LIFTY SR DS

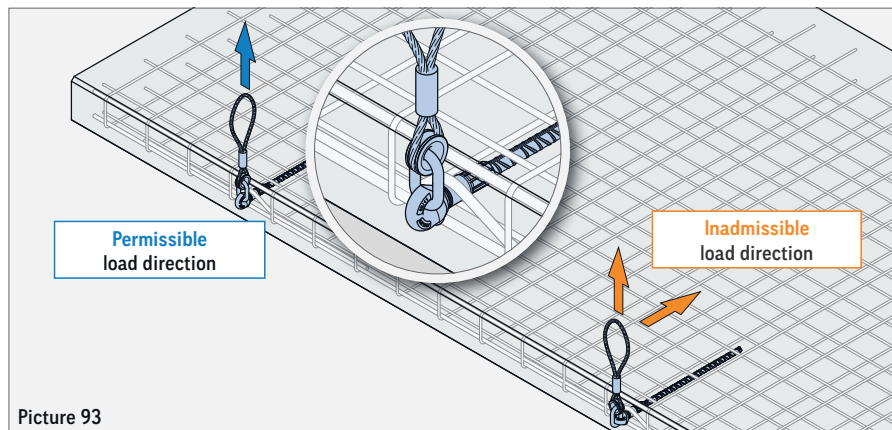

Picture 93

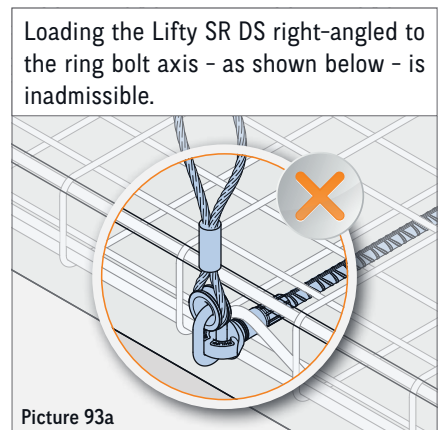

Picture 93a

USE OF ONLY ONE LIFTING DEVICE

Using only one Lifty SR DS in order to lift concrete elements attention must be paid that the Lifty SR DS is protected against unscrewing (e. g. by using a guy or guide rope at the concrete element).

WELDING

Welding or other strong heat influences on the Lifty SR DS are not allowed.

SAFETY NOTICES

As each other lifting equipment and lifting device the Lifty SR DS is subject to an annual inspection (acc. to German DGUV regulation 109-017, para. 8.2). This inspection lies within the responsibility of the owner and has to be done by an expert.

In general, the current accident prevention regulations must be observed. The correct hook size and form should be considered in order to extend the durability.

TRANSITION RADII

The transition radii of the load hooks must be at least the rope diameter of the Lifty SR DS (picture 94). The use of too small, too large or sharp-edged hooks leads to a reduced lifetime of the lifting device (replacement criteria).

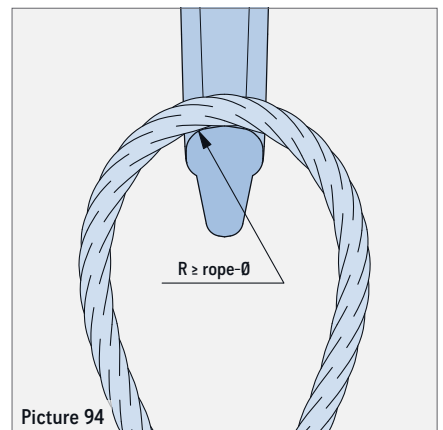

Picture 94

If the Lifty SR DS is loaded with extreme loads (e. g. by an event causing damage) which may have influenced the bearing capacity it must be examined extraordinarily by an expert.

CONTINUED USE

The continued use of damaged lifting devices or equipment already met the discard criteria is not permitted!

SAFETY NOTES / INSPECTION

Lifty SR and Lifty SR DS are lifting devices and are subject to an annual inspection (acc. to German regulation DGUV 109-017, para. 8.2). This inspection lies within the responsibility of the owner and has to be done by an expert. In general, the current accident prevention regulations must be observed. The correct hook size and form should be considered in order to extend the durability. The replacement state of the Lifty SR and Lifty SR DS follows the German DGUV regulation 109-017, para. 8.4.

REPLACEMENT STATE OF LIFTY SR AND LIFTY SR DS

During inspection the following points have to be considered:

- » Breakage of chain link
- » Deformed or bent chain link
- » Pressure marks on chain link caused by rigging hardware
- » Cracks or capacity reducing corrosion pits
- » Damaged thread
- » Twisted threaded bolt
- » Welding or other strong heat influences
- » Marking not readable any more
- » Exceeding or dropping below the permissible test dimensions

The chain link has to be checked for any elongation or diameter reduction (picture 96). The replacement state is reached when the chain link has an elongation of 5 % or the diameter of the link has a taper of 10 % (wear measurements, table 28).

TABLE 28: TEST DIMENSIONS OF THE CHAIN LINK

Type	T (mm)	T _{max} (mm)	Ød (mm)	d _{min} (mm)
SR12 / 16	115	121	13	11.7
SR20 / 24	115	121	16	14.4
SR30 / 36	115	121	22	19.8
SR42 / 52	139	146	26	23.4

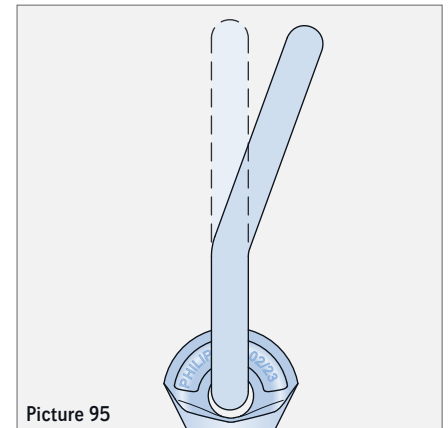

Picture 95

$$\frac{d_1 + d_2}{2} > d_{\min}$$

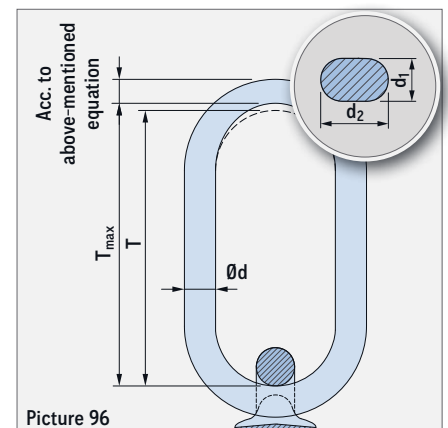

Picture 96

SAFETY NOTICES / INSPECTION

REPLACEMENT STATE OF LIFTY SR / LIFTY SR DS

Prior inspection the Lifty SR DS must be cleaned and the following points have to be considered:

- » Cracks or the capacity reducing corrosion pits
- » In the event of plastic deformation (e.g. bent threaded pin), the Lifty SR DS is ready for discarding
- » Dropping below the permissible test dimensions the replacement state is also reached
- » Broken strand
- » Kinks and bends
- » Loosening of external layer
- » Contusion in free lengths
- » Contusions in the support area of the eye with more than 4 broken wires
- » Damaged or deformed wire rope connection or threaded area (e.g. twisted ring bolt)
- » 4 broken wires on a length of the threefold of the wire rope diameter
- » 6 broken wires on a length of the sixfold of the wire rope diameter
- » 16 broken wires on a length of the thirtyfold of the wire rope diameter

WEAR MEASUREMENTS

During the inspection the wear of the thread pin diameter as well as the thimble shall be checked. The replacement state for this part is reached when the forged ring bolt or the thimble has a diminution of 10 % (picture 97 and 98, table 29 and table 30).

TABLE 29: WEAR MEASUREMENTS OF THE THIMBLE

Type	d_K (mm)	$d_K \times 0.9$ (mm)
SR 12	13.0	11.7
SR 16	19.0	17.1
SR 20	24.0	21.6
SR 24	24.0	21.6
SR 30	30.5	27.5
SR 36	30.5	27.5
SR 42	42.5	38.5

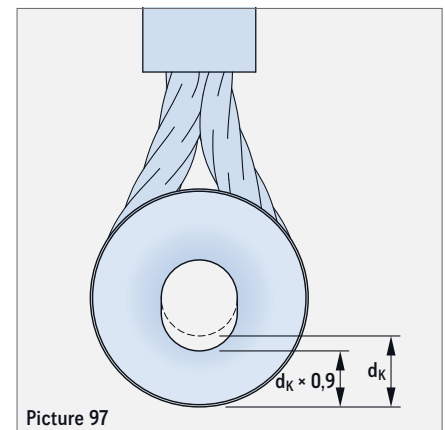

During the inspection of the ring bolt, the wear of the thread pin diameter shall be checked. The replacement state for this part is reached when the forged ring bolt has a diminution of 10 % (picture 98 and table 30). The outer diameter of the thread must also be checked acc. to picture 98 and table 30.

TABLE 30: WEAR MEASUREMENTS OF THE RING BOLT

Type	$d_{M,min}$ (mm)	d_R (mm)	$d_{R,min}$ (mm)
SR 12	11.50	16	14.4
SR 16	15.45	16	14.4
SR 20	19.40	22	19.8
SR 24	23.40	22	19.8
SR 30	29.40	32	28.8
SR 36	35.40	32	28.8
SR 42	41.20	39	35.1
SR 52	51.20	39	35.1

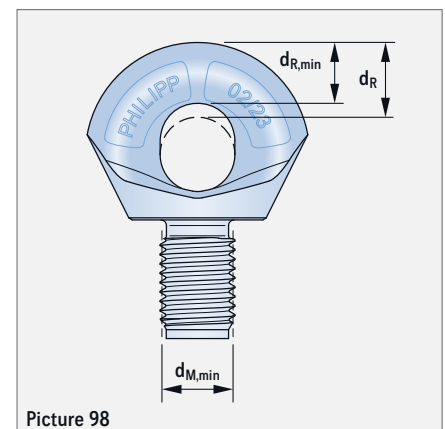

NOTES

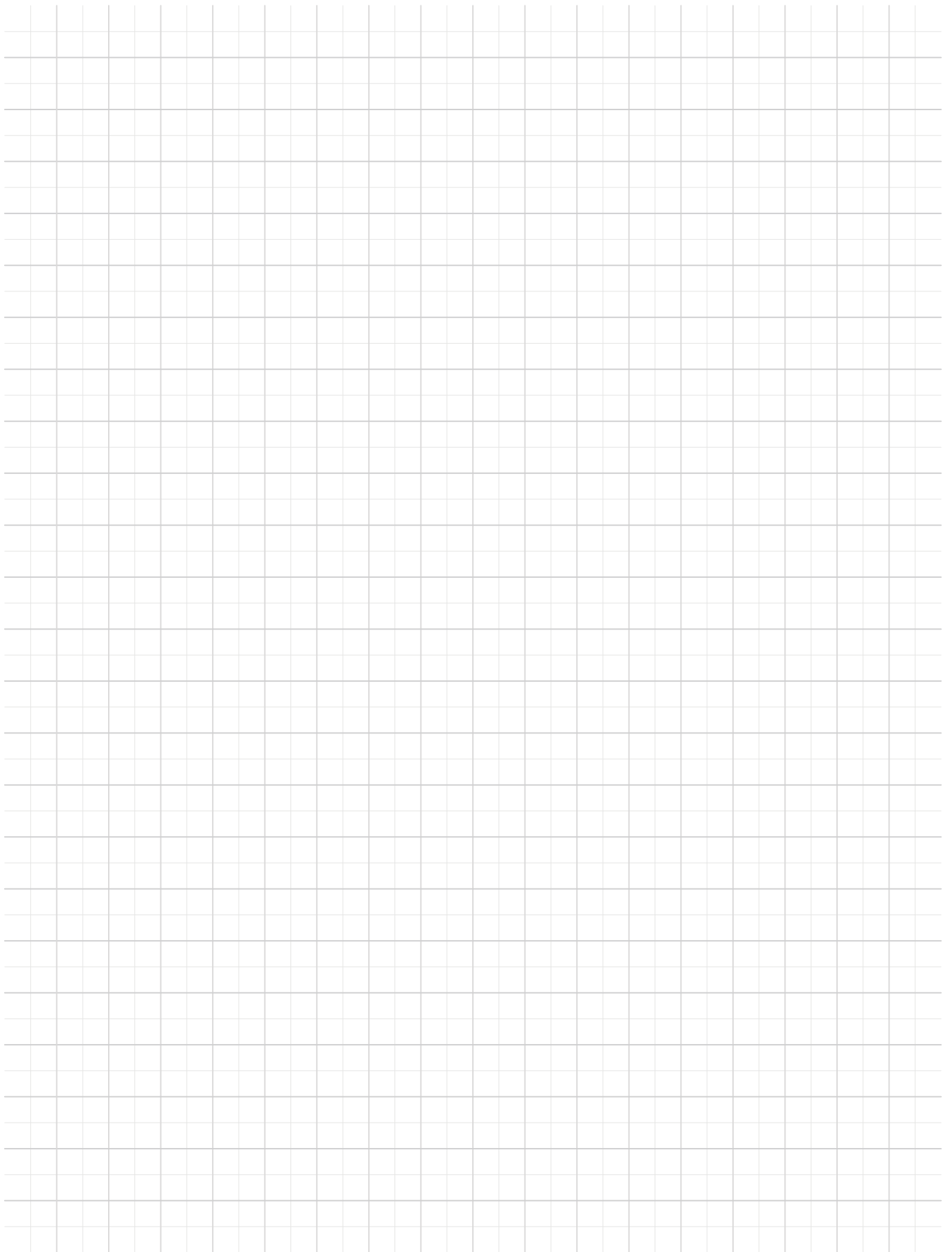

HEADQUARTERS

Lilienthalstraße 7-9
63741 Aschaffenburg
☎ +49 6021 40 27-0
✉ info@philipp-gruppe.de

PRODUCTION AND LOGISTICS

Hauptstraße 204
63814 Mainaschaff
☎ +49 6021 40 27-0
✉ info@philipp-gruppe.de

OFFICE COSWIG

Roßlauer Straße 70
06869 Coswig / Anhalt
☎ +49 34903 6 94-0
✉ info@philipp-gruppe.de

OFFICE NEUSS

Sperberweg 37
41468 Neuss
☎ +49 2131 3 59 18-0
✉ info@philipp-gruppe.de

OFFICE TANNHEIM

Robert-Bosch-Weg 12
88459 Tannheim / Allgäu
☎ +49 8395 8 13 35-0
✉ info@philipp-gruppe.de

PHILIPP VERTRIEBS GMBH

Pfaffing 36
5760 Saalfelden / Salzburg
☎ +43 6582 7 04 01
✉ info@philipp-gruppe.at



HEADQUARTERS Aschaffenburg



Visit us! www.philipp-group.de